



Unified Development Code

Planning & Zoning Department

Tree Technical Manual: Standards and Specifications
CITY OF EDINBURG, TEXAS
OCTOBER 1, 2007

Planning & Zoning Department

Tree Technical Manual: Standards and Specifications
City of Edinburg, Texas
OCTOBER 1, 2007**TABLE OF CONTENTS**

Introduction	v
Section 1: Tree Survey Standards.	vi
1.1. Introduction	vi
1.2. Protected and unprotected trees	vi
1.3. Types of tree surveys	vi
1.4. Tree survey certification	vi
1.5. Information to be gathered in the field	vi
1.6. Information to be provided on the tree survey	viii
1.7. Additional information	viii
Section 2: Tree Protection Standards	x
2.1. Introduction	x
2.2. Critical Root Zone (CRZ)	x
2.3. Tree Protection and Preservation Plan & pre-construction requirements	xi
2.3.1. Site plan reflecting Critical Root Zones	xi
2.3.2. Tree protection notes	xi
2.3.3. Pre-Construction meeting	xiii
2.3.4. Verification of tree protection	xiii
2.3.5. Tree fencing for protected trees	xiv
2.4. Tree pruning, tree surgery, and removal prior to construction	xviii
2.4.1. Pruning	xviii
2.4.2. Tree surgery	xx
2.4.3. Tree removal adjacent to protected trees	xx
2.5. Activities during construction and demolition near trees	xx
2.5.1. Soil compaction	xx
2.5.2. Grading limitations within the Critical Root Zone	xxi
2.5.3. Trenching, excavation, and equipment use	xxii
2.5.4. Tunneling and directional drilling	xxiii

Planning & Zoning Department

2.5.5. Construction impact mitigation _____	xxiv
2.6. Damage to trees _____	xxv
2.6.1. Reporting _____	xxv
2.6.2. Penalty for damage to protected trees _____	xxv
2.7. Pavement and hardscape conflicts with tree roots _____	xxv
2.7.1. Removal and replacement of pavement and sidewalks _____	xxv
2.7.2. Alternative methods to prevent root cutting (Recommended) _____	xxv
2.7.3. Avoiding conflicts (Recommended) _____	xxvi
2.7.4. Alternative base course material (Recommended) _____	xxvi
Section 3: Tree Removal, Replacement, Planting, and Maintenance Standards _____	xxvi
3.1. Introduction _____	xxvi
3.2. Tree removal _____	xxvi
3.2.1. Allowable removal _____	xxvi
3.2.2. Protected Tree Removal Permit Application _____	xxvi
3.3. Tree replacement plan _____	xxvii
3.4. Tree planting requirements _____	xxviii
3.4.1. Species _____	xxviii
3.4.2. Planting distances/spacing requirements _____	xxviii
3.5. Tree stock and materials _____	xxix
3.5.1. Quality _____	xxix
3.5.2. Container grown/ ball and burlapped trees _____	xxx
3.5.3. Miscellaneous materials _____	xxx
3.6. Planting site preparation _____	xxx
3.6.1. Soil preparation and conditioning _____	xxx
3.6.2. Planter pit preparation _____	xxx
3.6.3. Drainage _____	xxx
3.6.4. Aeration tubes for trees _____	xxx
3.7. Planting the tree _____	xxx
3.7.1. Container grown trees _____	xxx
3.7.2. Ball and burlapped trees _____	xxx
3.7.3. Backfill soil, amended soil _____	xxx
3.7.4. Filling the hole _____	xxx

Planning & Zoning Department

3.7.5. Constructing a berm or dam _____	xxxii
3.7.6. Mulching _____	xxxii
3.7.7. Staking or guying _____	xxxiii
3.8. Pruning new trees _____	xxxiv
3.8.1. Prohibitions _____	xxxiv
3.8.2. Pruning guidelines (Recommended) _____	xxxiv
3.8.3. Limb removal (Recommended) _____	xxxiv
3.9. Transplanting trees _____	xxxv
3.10. Irrigation _____	xxxvi
3.11. Maintenance _____	xxxvi
Section 4: Administration, Inspection, and Enforcement _____	xxxvii
4.1. Administration _____	xxxvii
4.2. Inspection _____	xxxvii
4.2.1. Inspection by owner _____	xxxvii
4.2.2. Inspection by city representative _____	xxxvii
4.3. Enforcement _____	xxxviii
Appendix	
A. Definitions _____	xxxix
B. List of Approved Trees for Planting in the City of Edinburg _____	xlii
C. Bibliography _____	xlili
D. Protected Tree Removal Permit Form _____	xliv

Planning & Zoning Department**INTRODUCTION**

Trees provide numerous benefits to quality of life in the urban area, such as beautification, energy conservation, and increased property values. The City of Edinburg recognizes the value of trees to the community. On August 6, 2007, the Edinburg City Council adopted the Unified Development Code. The Unified Development Code includes Tree Preservation standards in order to preserve trees on property under development or already developed. The Unified Development Code, Tree Preservation Standards are the City's primary regulatory tool to provide for orderly protection of specified trees, to promote the health, safety, welfare, and quality of life for the residents of the City, to protect property values, and to avoid significant negative impacts on adjacent properties.

By assuring preservation and protection through regulations and standards of care, these resources will remain significant contributions to the landscape, streets, and parks, and continue to help define the unique character of Edinburg. This *Tree Technical Manual* is published separately from the Unified Development Code and is maintained by the Planning and Zoning Department with distribution by the Forestry Manager.

The Manual provides standards and specifications based on generally accepted practices and provides guidelines for survey, protection, planting, pruning, and irrigation of trees. If there appears to be a conflict in verbiage between the Unified Development Code and the Manual, the Unified Development Code will take precedence. The goals of the Manual are intended to provide consistent care and serve as benchmarks to measure achievement in the following areas:

- Ensure and promote preservation of the remaining tree canopy cover within the City limits
- Provide standardized presentation of tree survey data required by the City
- Increase the survivability of trees during and after construction events by providing protection standards and best management practices
- Provide standards for the replacement of trees that are permitted to be removed
- Provide standards for new tree planting, tree care, and irrigation
- Provide guidance on protection, planting, and care of trees in the city's right-of-way and publicly owned lands
- Establish criteria for determining when a tree is hazardous and a possible threat to the public health, safety and welfare

PRIMARY SOURCES CONSULTED

Standards and specifications were gathered from various sources as listed in the bibliography. The International Society of Arboriculture (ISA) material was used for much of the tree planting, pruning, and general tree care information. This *Tree Technical Manual is based on the Tree Technical Manual* produced by the Round Rock Texas on 2005. The resultant standards in this Manual are based on common practices in the area and the types of soils and trees that exist in Edinburg. Special recognition is given to the Texas Forest Service, the Texas Agricultural

Extension personnel and members of the City's Environmental Committee who contributed their expertise to develop this Manual.

SECTION 1: TREE SURVEY STANDARDS

1.1. INTRODUCTION

This section describes the format of tree surveys as well as the types of tree identification required in the field. These standards and specifications assure a faster review process as they relate to tree protection and mitigation.

1.2. PROTECTED AND UNPROTECTED TREES

Trees of all species that are at least eight (8) inches in diameter are protected except for Brazilian Pepper, Chinaberry, Chinese Tallow, Salt Cedar and exceptions as outlined Section 10.601 of the Unified Development Code. For details related to protected trees, refer to the Unified Development Code.

There are three groupings based on size or designation within the protected tree family. The first group includes trees with diameters of 8-19.99 inches. The second group includes trees with diameters of 20 inches and above. The third group includes the "Champion" tree as described in Section 10.601 of the Unified Development Code. In Section 10.601. B. of the Unified Development Code, Trees less than eight (8) inches in diameter are not protected. However, healthy trees (good branching structure, height, and spread similar to nursery grown trees) with diameters of 3-7 inches may be credited toward mitigation.

Additionally, healthy trees with diameters of 3-19 inches may be credited toward mitigation. The trees selected for mitigation will be indicated on the tree survey and construction plans and will be protected in the same manner as a protected tree. The Forestry Manager will approve the trees recommended for mitigation.

1.3 TYPES OF TREE SURVEYS

There are two types of tree surveys, partial and full. Elements required in a partial tree survey are described in the definition of Partial Tree Survey.

1.4 TREE SURVEY CERTIFICATION

All tree surveys shall be certified. The tree survey will be performed by a certified arborist, registered landscape architect, or a registered professional land surveyor.

Protected trees over eight inches will be surveyed and reflected on the survey graphically and in the legend. Protected species of trees under eight (8) inches used for replacement credit will be illustrated on the survey and legend as well. If it is found upon field inspection that the survey is inaccurate, the tree survey will not be accepted and reviewed and will be returned for corrections. This will delay the building permit, site plan or plat review process while the tree survey is corrected and approved.

1.5. INFORMATION TO BE GATHERED IN THE FIELD

The data required to be collected and illustrated in the site plan include tree locations, diameters, species, limits of construction, and certain tree graphics.

1. **Location**- Tree data submitted must be obtained from a ground survey. A number shall be assigned and a corresponding numbered tag placed on each tree surveyed and provided in the overall tree survey. Tree numbers will remain on the trees until the project has received its certificate of occupancy.

2. **Diameter**-Diameters of existing trees are measured as follows. Diameter measurement should be recorded to the nearest inch. Trees may be measured with a caliper, cruise stick, standard tape measure or diameter tape.

Illustration 1-1: Measurement of trees

From: *Guide for Plant Appraisals, 9th ed.*

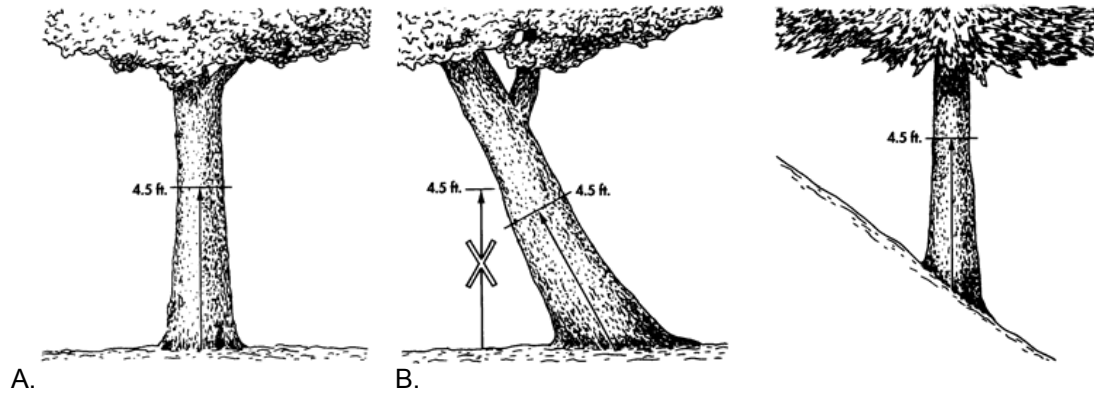

a. Straight trunk: Trees with fairly straight, upright trunks should be measured four and a half (4.5) feet above the ground (See illustration 1-1 A).

b. Trunk on an angle or on a slope: The trunk is measured at right angles to the trunk four and a half (4.5) feet along the center of the trunk axis, so the height is the average of the shortest and the longest sides of the trunk (see Illustration 1-1 B).

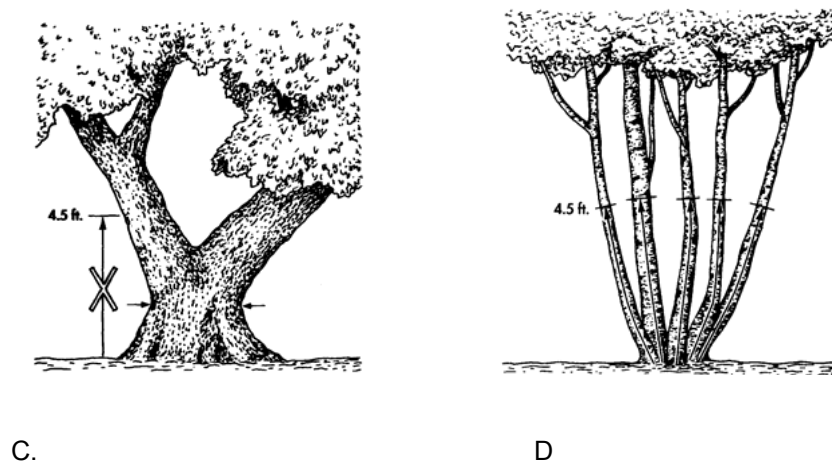

c. Trunk branching lower than four and a half (4.5) feet from the ground: When branching begins less than four and a half (4.5) feet from the ground, measure the smallest circumference below the lowest branch. In this example, an alternative would be to add the sum of the cross-sectional areas of the two stems measured about 12 inches above the crotch. Then average the sum of these two branch areas and the smallest cross-sectional area below the branches. This may give a better estimate of the tree size (see Illustration 1-1 C).

d. Multi-stemmed tree: To determine the diameter of a multi-trunk tree, measure all the trunks; add the total diameter of the largest trunk to one-half (1/2) the diameter of each additional trunk (see Illustration 1-1 D). A multi-trunked tree is differentiated from individual trees growing from a common root stock if there is a visible connection between the trunks above ground.

3. **Species-** The name of the species, such as Mesquite, Live Oak, Cedar Elm, or Hackberry, should be accurately reflected. Tree types may be listed by common names or Latin names. Indicating a tree name as “unknown” on a tree survey is not acceptable.

1.6. INFORMATION TO BE PROVIDED ON THE TREE SURVEY

1. **Trunk location-** The trunk location on the plan must represent the center of the trunk at ground level in the field. If the tree leans substantially above that point, show the direction of the lean with an arrow. See the legend under the sample Tree Survey in Illustration 1-2 for an example.

2. **Critical Root Zone (CRZ)-** Trees are to be represented on the tree survey by a concentric circle centered on the trunk location, with a radius equal in feet to the number of inches of the tree’s trunk diameter. For example, an oak tree with a trunk diameter measuring fifteen (15) inches would be represented to scale on the tree survey with a circle representing a fifteen (15) foot radius. Trees to be retained will be represented by a solid circle. Trees to be removed are to be represented by a dashed circle. See Illustration 1-2.

3. **Diameters and types of existing trees-** Tree diameters and types shall be shown on the survey through a legend. Tree numbers on the legend will be correlated with the appropriate tree circle drawn on the plan and the trees in the field. Trees to be removed will be highlighted in bold print. Special conditions such as “dead” will be noted.

4. **Tree numbers-** Tree numbers on the plan will correlate with tags assigned to trees during the survey.

5. **Tree survey table:** A table will be included listing all surveyed trees by number, species, sizes, removal status, health conditions, and credit trees under eight inches. It will also include a legend indicating the protection status of the tree. Additionally, it will include calculations of the number of inches of trees to be protected, inches to be removed without mitigation, number of inches under 20 inches, number of inches over 20 inches, number of inches subject to mitigation, and number of inches credited. See illustration 1-2 for reference.

1.7. ADDITIONAL INFORMATION

There are other types of information related to tree structure and condition which may affect site plan design. The Forestry Manager may request these types of information. The information will be expressed as a written note on the survey and include the tree number and a description of any of the following:

1. **Crown configuration-** If a tree has a crown which is skewed in one direction, this information would be useful for surveyors to note. Project designers and plan reviewers need such information to more accurately assess design impacts on such trees.

2. **Crown Clearance-** This information is often critical in determining whether a given structure or vehicular use area can practically be placed within the drip line of a tree. If this information is recorded, the surveyor should consider the vertical distance to any major branches.

3. **Condition-** This is one of the principle factors in determining whether a tree should or should not be preserved. Surveyors should not speculate about the condition of all trees unless they have the necessary credentials; however if a tree is obviously in poor condition, it should be noted to prevent unnecessary expense in trying to design around it.

4. **Spot elevation-** Taking an elevation reading near the trunks of some trees will provide valuable information for project designers. Since grade changes are the most destructive impacts on trees, it is important to get the most accurate information possible. If there is more than a six inch change, existing and proposed grade elevation will need to be reflected on the tree survey.

Illustration 1-2: Elements of a Tree Survey

TREE SURVEY TABLE

Key Tree # Size—Species

R 1 8" – Live Oak

NP 2 10" – Hackberry – not protected

P 3 16" – Post Oak

P 4 36" – Cedar Elm

P 5 20" – Live Oak

NP 6 20" – Chinaberry – not protected

R-D 7 40" – Live Oak – Dead – not calculated

P 8 12" – Silver leaf maple

P 9 12" – Pecan

P 10 40" – Pecan

NP-C 11 7" – Pecan - Credit

NP-C 12 4" – Bur Oak - Credit

NP-C 13 5" – Live Oak – Credit

LEGEND P- Protected

R- Removal of Protected Tree

R-D- Removed due to death or disease

NP- Not Protected Species

NP-C- Not Protected, Credit

Total inches protected trees on site: 144

Total inches that may be removed without replacement: 43

Trees under 20 Inches, total inches removed: 20

Inches subject to replacement: 20

Trees 20+ inches, total inches removed: 20

Inches subject to replacement: 60

Total tree inches credited: 16

Total inches to be replaced: 21

20 + 60 = 80 to be replaced

80 - 43 = 37 to be replaced without the tree credit

37 - 16 = 21 to be replaced with the tree credit

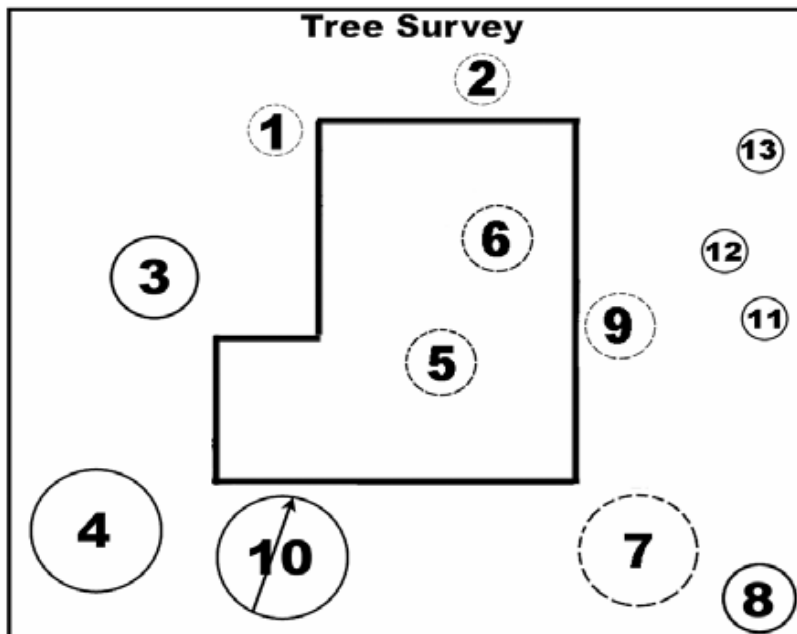

- Legend:**
- 4 **Tree to remain**
 - 7 **Tree to be removed**
 - 10 **Tree to remain, direction of lean**

SECTION 2: TREE PROTECTION STANDARDS

2.1. INTRODUCTION

The tree protection section of the Ordinance and the standards in this section are provided to ensure that appropriate practices will be implemented in the field to eliminate undesirable consequences that may result from uninformed or careless acts, and preserve both trees and property values. Construction projects are required to implement the protective practices described in this section.

Typical negative impacts that may occur during construction include:

- Mechanical injury to roots, trunk or branches
- Compaction of soil, which degrades the functioning roots and inhibits the development of new ones and restricts drainage, which desiccates roots and enables water mold fungi to develop
- Changes in existing grade which can cut or suffocate roots
- Alteration of the water table - either raising or lowering
- Microclimate change, exposing sheltered trees to sun or wind
- Sterile soil conditions, associated with stripping off topsoil

2.2. CRITICAL ROOT ZONE (CRZ)

Each tree to be retained shall have a designated CRZ identifying the area sufficiently large enough to protect the tree and roots from disturbance. The CRZ is defined as a radius equal in feet to the number of inches of the tree's trunk diameter, with a minimum of eight (8) feet. The CRZ shall be shown on all tree surveys, tree replacement plans, and construction plans. Improvements or activities such as paving, utility and irrigation trenching and other activities shall occur outside the CRZ, unless authorized by the Forestry Manager. Unless otherwise specified, the protective fencing shall define the CRZ.

Illustration 2-1: Root zone vs. Critical root zone (CRZ)

From: Urban Forest Management Plan.

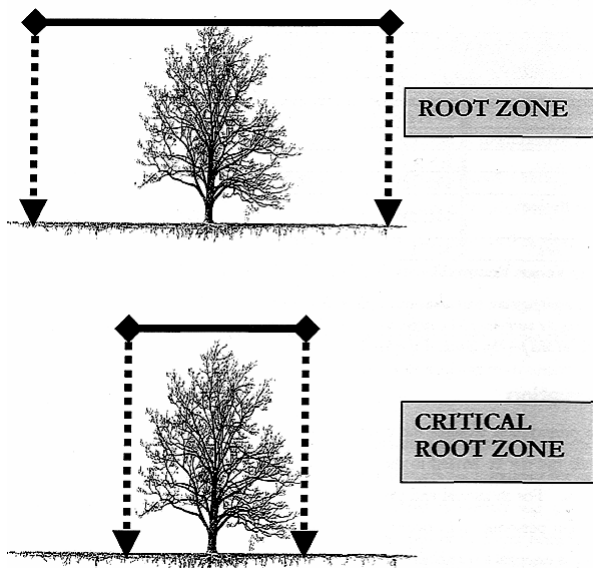

Activities prohibited within the CRZ include:

- Storage or parking vehicles, building materials, refuse, excavated spoils or dumping of poisonous materials on or around trees and roots. Poisonous materials include, but are not limited to, paint, petroleum products, concrete or stucco mix, dirty water or any other material which may be harmful to tree health
- The use of tree trunks as a winch support, anchorage, temporary power pole, sign posts or other similar function
- Cutting of tree roots by utility trenching, foundation digging, placement of curbs and trenches and other miscellaneous excavation without prior approval of the

Forestry Manager

- Soil disturbance or grade change
- Impervious paving
- Vehicular traffic
- Drainage changes

Activities permitted or required within the CRZ include:

- Mulching. During construction, mulch may be spread within the CRZ. The mulch may be removed if improvements or other landscaping is required. Where there are areas of unprotected root zones in the CRZ, those areas shall be covered with four (4) inches of organic mulch to minimize soil compaction. See Chapter 3 of this Manual for a more thorough discussion on mulching.
- Irrigation, aeration, fertilizing or other beneficial practices that have been specifically approved for use within the CRZ and as defined by the Forestry Manager.
- Erosion Control. If a tree is adjacent to or in the immediate proximity to a grade slope of 8% (23 degrees) or more, then approved erosion control or silt barriers shall be installed outside the CRZ to prevent siltation and/or erosion within the CRZ.

2.3. TREE PROTECTION AND PRESERVATION PLAN & PRE-CONSTRUCTION REQUIREMENTS

Prior to the start of any development project, the property owner shall have prepared and submitted for review a Tree Protection Plan for all protected trees. The Tree Protection Plan will consist of three elements: 1) illustrations showing options in tree fencing and protection (see illustrations in this section related to fencing and protection), 2) notes as listed in section 2.3.2 of this Manual, and 3) tree protection symbols on the tree protection plan as discussed in section

2.3.1 and illustrated in Illustration 2-2 of this Manual. The plan will be reviewed by the Forestry Manager. The following elements will be addressed in the Tree Protection Plan prior to construction:

2.3.1. Site Plan Reflecting Critical Root Zones

In addition to the requirements described in the Tree Survey Standards, the CRZ to be enclosed with the specified tree fencing will be indicated on the Tree Replacement Plan and all construction plans as a bold dashed line with a TP placed between dashes (see Illustration 2-2).

2.3.2. Tree Protection Notes

The Construction Plan and Site Plan will reflect the following tree protection notes. The following notes must be shown on plans accompanied by the tree protection details as illustrated on pages 2-5 through 2-9.

1. All trees not located within the limits of construction and outside of disturbed areas shall be preserved.
2. All trees shown on this plan to be retained shall be protected during construction with fencing.
3. Tree protection fences shall be erected according to city standards for tree protection, including types of fencing and signage.
4. Tree protection fences shall be installed prior to the commencement of any site preparation work (clearing, grubbing, or grading) and shall be maintained throughout all phases of the construction project.
5. Erosion and sedimentation control barriers shall be installed or maintained in a manner which does not result in soil build-up within tree driplines.
6. Fences shall completely surround the tree or clusters of trees, located at the outermost limits of the tree branches (dripline) or CRZ, whichever is greater; and shall be maintained throughout the construction project in order to prevent the following:
 - a. Soil compaction in root zone area resulting from vehicular traffic or storage of equipment or material.
 - b. Root zone disturbances due to grade changes (greater than 6 inches cut or fill) or trenching not reviewed and authorized by the Forestry Manager.
 - c. Wounds to exposed roots, trunk, or limbs by mechanical equipment
 - d. Other activities detrimental to trees such as chemical storage, concrete truck cleaning, and fires.
7. Exceptions to installing tree fences at the tree driplines or CRZ, whichever is greater, may be permitted in the following cases:
 - a. Where there is to be an approved grade change, impermeable paving surface, or tree well;
 - b. Where permeable paving is to be installed, erect the fence at the outer limits of the permeable paving area.
 - c. Where trees are close to proposed buildings, erect the fence no closer than 6 feet to the building.
 - d. Where there are severe space constraints due to tract size, or other special requirements, contact the Forestry Manager to discuss alternatives.
8. Where any of the above exceptions result in a fence that is closer than 5 feet to a tree trunk, protect the trunk with strapped-on planking to a height of 8 feet (or to the limits of lower branching) in addition to the reduced fencing provided.
9. Where any of the above exceptions result in areas of unprotected root zones under the dripline or CRZ, whichever is greater, those areas should be covered with 4 inches of organic mulch to minimize soil compaction.
10. All grading within protected root zone areas shall be done by hand or with small equipment to minimize root damage. Prior to grading, relocate protective fencing to 2 feet behind the grade change area.
11. Any roots exposed by construction activity shall be pruned flush with the soil. Backfill root areas with good quality top soil within two days. If exposed root areas are not backfilled within 2 days, cover them with organic material in a manner which reduces soil temperature and minimizes water loss due to evaporation.
12. Prior to excavation or grade cutting within tree driplines, a clean cut shall be made between the disturbed and undisturbed root zones with a rock saw or similar equipment to minimize damage to remaining roots.

13. Trees most heavily impacted by construction activities will be watered deeply once a week during periods of hot, dry weather. Three crowns are to be sprayed with water periodically to reduce dust accumulation on leaves.

14. When installing concrete adjacent to the root zone of a tree use a plastic vapor barrier behind the concrete to prohibit leaching of lime into the root zone.

15. Any trenching required for the installation of landscape irrigation shall be placed as far from existing tree trunks as possible.

16. No landscape topsoil dressing greater than four (4) inches shall be permitted within the dripline or CRZ, whichever is greater, of trees. No topsoil is permitted on root flares of any tree.

17. Pruning to provide clearance for structures, vehicular traffic, and construction equipment shall take place before construction begins. All pruning must be done according to city standards and as outlined in literature provided by the International Society of Arboriculture (ISA pruning techniques).

18. All oak tree cuts, intentional or unintentional, shall be painted with earth tone colors. Tree paint must be kept on site at all times.

19. The Forestry Manager has the authority to require additional tree protection before or during construction.

20. Trees approved for removal shall be removed in a manner which does not impact trees to be preserved. Refer to the City of Edinburg *Tree Technical Manual* for appropriate removal methods.

21. Prior to construction all lower tree limbs over roadways must be pruned to a height of 14 feet height using the techniques described in the City of Edinburg *Tree Technical Manual*.

22. Deviations from the above notes may be considered ordinance violations if there is substantial noncompliance or if a tree sustains damage as a result.

2.3.3. Pre-construction meeting

The demolition, grading and underground contractors, construction superintendent and other pertinent personnel are required to meet with the Forestry Manager or his designee prior to beginning work to review procedures, tree protection measures and to establish haul routes, staging areas, contacts, watering, etc.

2.3.4. Verification of tree protection

The project arborist, landscape architect or contractor shall verify, in writing, that all preconstruction conditions have been met (tree fencing, erosion control, pruning, etc.) and are in place. Written verification must be submitted to and approved by the Forestry Manager before demolition or grading begins.

Illustration 2-2: Site plan with tree protection fence illustrated as —TP—. Circles illustrate the Critical Root Zone.

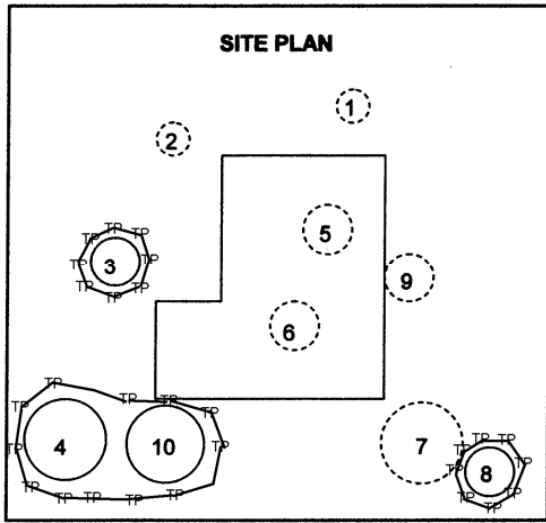

2.3.5. Tree fencing for protected trees

Fenced enclosures shall be installed at the CRZ or the dripline, whichever is greater, to achieve three primary goals:

1. To keep the foliage crowns and branching structure clear from contact by equipment, materials and activities
2. To preserve roots and soil conditions in an intact and non-compacted state; and
3. To identify the Critical Root Zone (CRZ) in which no soil disturbance is permitted and activities are restricted, unless otherwise approved.

**Illustration 2-3: Examples of tree protection fencing surrounding the Critical Root Zone—
General Instructions**

From: City of Austin

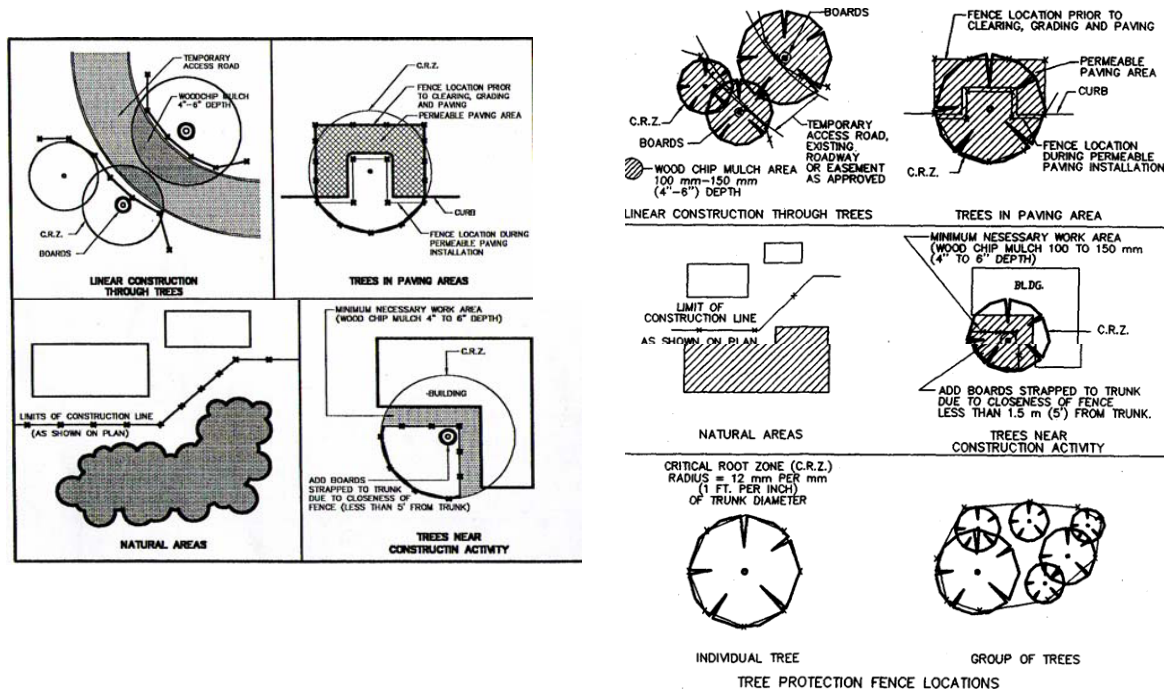

Illustration 2-4: Examples of tree protection fencing surrounding the Critical Root Zone—Wood fencing, without and with adjacent obstruction

Source: City of Austin

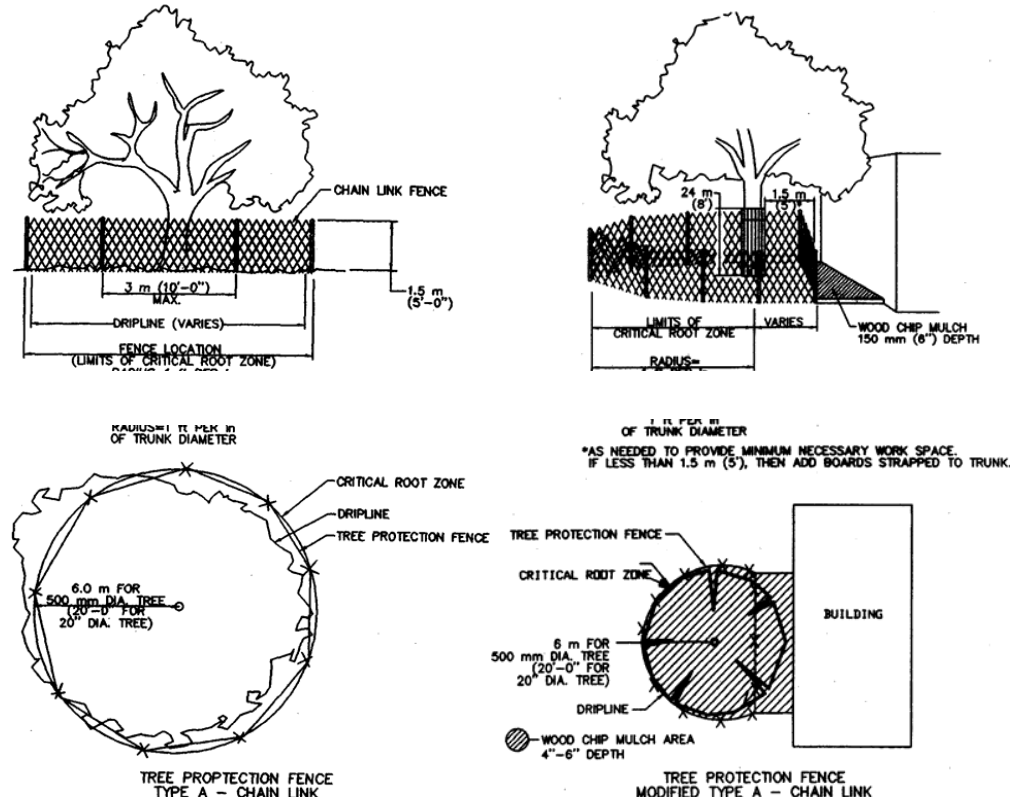
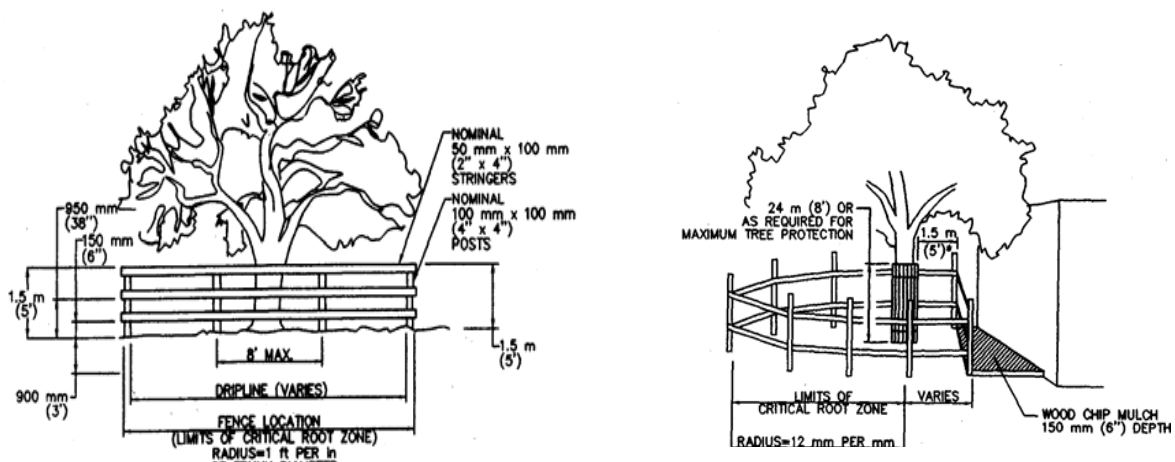
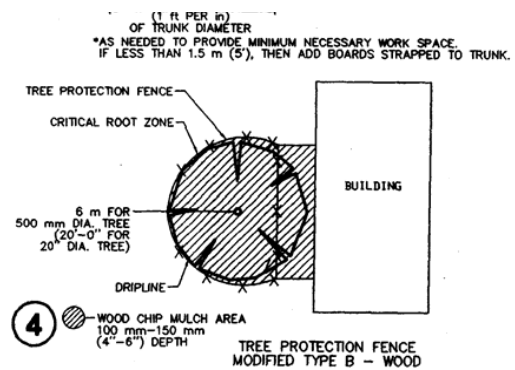
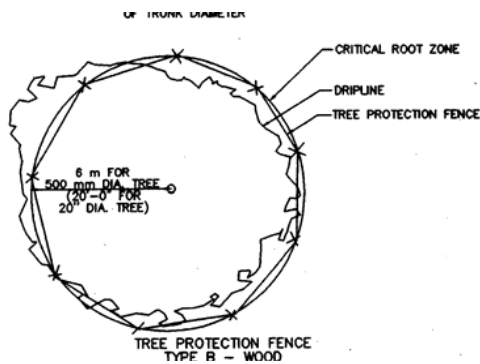

Illustration 2-5: Examples of tree protection fencing surrounding the Critical Root Zone—Wood fencing, without and with adjacent obstruction

Source: City of Austin





a. Exceptions to fencing along the CRZ

1. Where permeable paving is to be installed, erect the fence at the outer limits of the permeable area
2. Where trees are close to proposed buildings, erect the fence no closer than six (6) feet to the building
3. Where there are severe space constraints due to tract size, or other special requirements, contact the Forestry Manager

b. Size and type of fence

Chain Link:

Chain link fences around protected trees shall be a minimum of five (5) feet high. Fences are to be mounted on two inch diameter galvanized iron posts, driven into the ground to a depth of at least 1-foot at no more than 10-foot spacing. This detail shall appear on grading, demolition and improvement plans.

Wood:

Wood fencing will consist of vertical planks attached to 2x4 inch horizontal stringers which are supported by 2x4 inch intermediate vertical supports and a 4x4 inch post at every fourth vertical support.

c. Area to be fenced

1. Type I Tree Protection

The fences shall enclose the entire area under the **dripline or CRZ**, whichever is larger, of the tree(s) to be saved throughout the life of the project, or until final improvement work within the area is required, typically near the end of the project. Parking Areas: If the fencing must be located on paving or sidewalk that will not be demolished, the posts may be supported by an appropriate grade level concrete base.

2. Type II Tree Protection

For trees situated within a **narrow planting strip**, only the planting strip shall be enclosed with the required chain link or wood protective fencing in order to keep the sidewalk and street open for public use. For trees **situated near buildings**, partial fencing may be necessary. See Illustrations 2-4 and 2-5 for examples and specifications for partial wood and chain link fencing.

3. Type III Tree Protection

Trees situated in a small tree well or **sidewalk planter pit**, or when construction will come within five (5) feet of a trunk, shall have the trunk protected with strapped-on planking to a height of eight (8) feet or to the limits of lower branches. During installation of the wood slats, caution shall be used to avoid damaging any bark or branches. Major scaffold limbs may also need protection as directed by the Forestry Manager.

Illustration 2-6: Example of bark protection—done when CRZ is less than an 8 foot diameter, upon approval by the Forestry Manager.

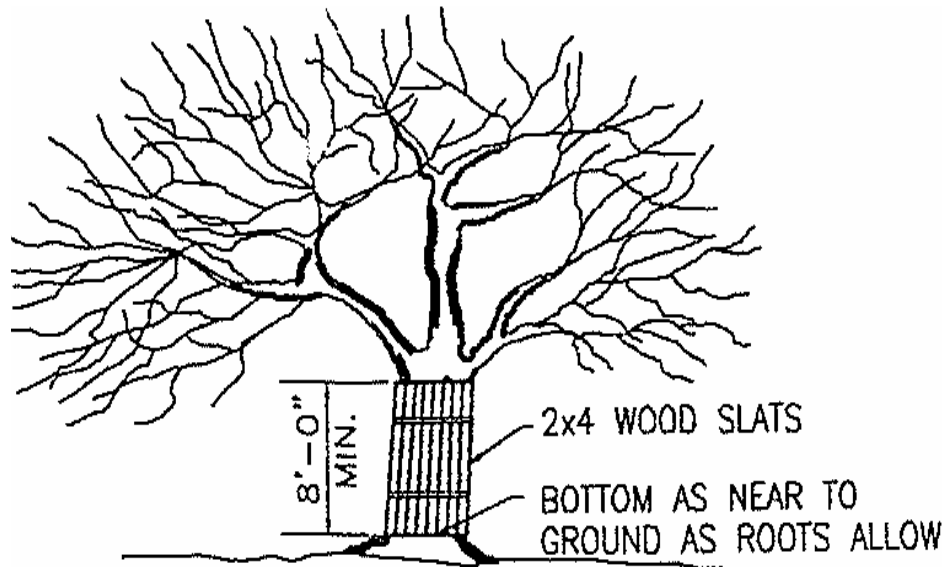

TREE TRUNK (BARK) PROTECTION: WOOD SLATS

d. Duration

Tree fencing shall be erected before demolition, grading, or construction begins and remain in place until the certificate of occupancy has been granted. Removal of the fence during construction must be approved by the Forestry Manager. **Fence removal without the approval of the Forestry Manager will result in a stop work order.**

e. 'Warning' sign

A warning sign shall be prominently displayed on each fence. The sign shall be a minimum of 16 x 24-inches and clearly state:

WARNING - Critical Root Zone - Encroachment may result in permanent tree damage resulting in tree replacement.

Illustration 2-7: Sample signage for CRZ area.

Illustration from: Conserving Wooded Areas in Developing Communities.

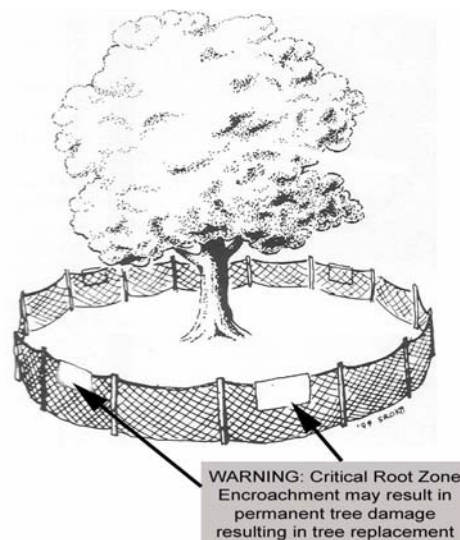

2.4. TREE PRUNING, TREE SURGERY, AND REMOVAL PRIOR TO CONSTRUCTION

2.4.1. Pruning

Prior to construction, various trees may require that branches be pruned clear from structures, activities, building encroachment or may need to be strengthened by means of mechanical support or surgery per approval of Forestry Manager. The most compelling reason to prune is to develop a strong, safe framework and tree structure. Cosmetic pruning is left to the discretion of the owner. Consult an arborist or landscape architect for best practices if cosmetic pruning is desired. However, practices such as limbing up should be avoided. Heavy pruning just after the spring growth flush should be avoided. This is when trees have just expended a great deal of energy to produce foliage and early shoot growth. Removal of a large percentage of foliage at this time can stress the tree.

a. All trees except oaks (Recommended):

Most routine pruning to remove weak, diseased, or dead limbs can be accomplished at any time during the year with little effect on the tree. As a rule, growth is maximized and wound closure is fastest if pruning takes place between November and February.

b. Oak trees:

Due to oak wilt disease, avoid pruning of all oak species in the spring and fall. Clean cutting tools with a disinfectant between each tree pruned. Tree pruning paint must be used on all pruning cuts on all oak species regardless of the time of year of pruning.

c. Pruning limitations:

1. Minimum pruning

If the project arborist or landscape architect recommends that trees be pruned, and the type of pruning is left unspecified, the standard pruning shall consist of 'crown cleaning' as described below. Trees shall be pruned to reduce hazards and develop a strong, safe framework.

2. Maximum Pruning

Maximum pruning should only occur in the rarest situation and be approved by the Forestry Manager. No more than one fourth (25 percent) of the functioning leaf and stem area may be removed within one calendar year of any protected tree. It must be recognized that trees are individual in form and structure, and that pruning needs may not always fit strict rules. The project arborist or landscape architect shall assume all responsibility for special pruning practices that vary from the standards outlined in this manual.

3. Tree Workers (Recommended)

Pruning shall not be attempted by construction or contractor personnel, but shall be performed by a qualified tree care specialist or certified arborist.

4. Types of pruning

i. Cleaning:

The removal of dead, dying, diseased, crowded, weakly attached, and low-vigor branches from the crown of a tree.

ii. Thinning:

The selective removal of branches to increase light penetration and air movement through the crown. Thinning opens the foliage of a tree, reduces weight on heavy limbs, and helps retain the tree's natural shape.

iii. Raising:

Removes the lower branches from a tree in order to provide clearance for buildings, vehicles, pedestrians, and vistas.

iv Reduction:

Reduces the size of a tree, often for clearance for utility lines. Reducing the height or spread of a tree is best accomplished by pruning back the leaders and branch terminals to lateral branches that are large enough to assume the terminal roles (at least 1/3 the diameter of the cut stem). Compared to topping, this helps maintain the form and structural integrity of the tree.

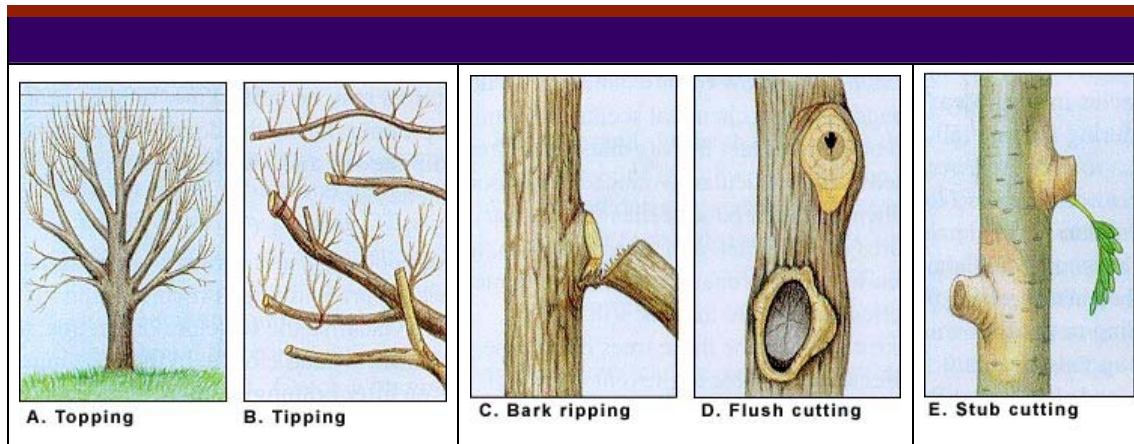
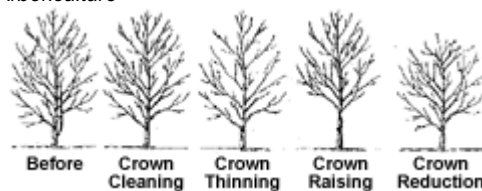

Illustration 2-8: Types of crown pruning

From: *International Society of Arboriculture*



5. Making Proper Pruning Cuts

- Tree topping is prohibited and may result in tree replacement.
- Stub cuts are prohibited.
- Cuts will be made just beyond the outer edge of the collar of live wood. See Illustration 2-9 for an example.
- Don't use pruning paint or so called wound dressings, except for tree pruning cuts on all oak species at all times due to the threat of oak wilt disease.

- If a large limb is to be removed, its weight should first be reduced. This is done by making an undercut about 12-18 inches from the limb's point of attachment. A second cut is made from the top, directly above or a few inches further out on the limb. This removes the limb leaving the 12-18 inch stub. The stub is removed by cutting back to the branch collar. This technique reduces the possibility of tearing the bark.

Illustration 2-9: Proper tree cuts

From: International Society of Arboriculture

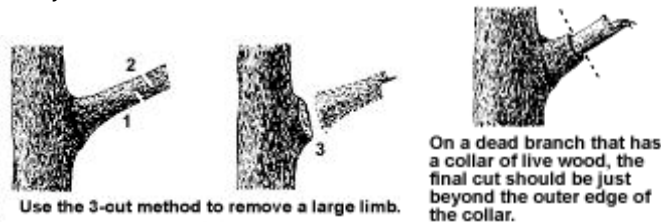

2.4.2. Tree Surgery

If it is necessary to promote health and prolong useful life or the structural characteristics, trees shall be provided the appropriate treatments (e.g.cavity screening, bark tracing, wound treatment, cables, rods or pole supports) as specified by the project arborist or landscape architect.

2.4.3. Tree Removal Adjacent to Protected Trees

When trees are removed and adjacent trees must be protected (as shown on the approved site plans), then the following tree removal practices apply:

a. Tree Removal

Removal of trees that extend into the branches or roots of protected trees shall not be attempted by demolition or construction personnel, grading or other heavy equipment. A certified arborist or tree worker shall remove the tree carefully in a manner that causes no damage above or below ground to trees that remain.

b. Stump Removal

Before performing stump extraction, the developer shall first consider whether or not roots may be entangled with trees that are to remain. If so, these stumps shall have their roots severed before extracting the stump.

Removal shall include the grinding of stump and roots to a minimum depth of 24- inches but expose soil beneath stump to provide drainage. In sidewalk or small planter areas to be replanted with a new tree, the entire stump shall be removed and the planting pit dug to a depth of 30- inches. If dug below 30-inches, compact the backfill to prevent settling. Large surface roots three feet from the outside circumference shall be removed, including the spoils and backfilled with City approved topsoil to grade, and the area tamped to settle the soil.

2.5. ACTIVITIES DURING CONSTRUCTION & DEMOLITION NEAR TREES

Soil disturbance or other injurious and detrimental activity within the CRZ is prohibited unless approved by the Forestry Manager. If an injurious event inadvertently occurs, or soil disturbance has been specifically conditioned for project approval, then the following mitigation is required:

2.5.1. Soil compaction

If compaction of the soil occurs, it shall be mitigated as outlined in Section 2.5.5.

2.5.2. Grading limitations within the Critical Root Zone-

- Grade changes within the CRZ are not normally permitted.
- If grading within the CRZ is approved, grading shall be done by hand or with small equipment to minimize root damage
- Grade changes outside the CRZ shall not significantly alter drainage to the tree
- Grade changes under specifically approved circumstances shall not allow more than four (4) inches of fill soil added or allow more than four (4) inches of existing soil to be removed from natural grade unless mitigated.
- Grade fills over four (4) inches or impervious overlay shall incorporate an approved permanent aeration system, permeable material or other approved mitigation.
- Grade cuts exceeding four (4) inches shall incorporate retaining walls or an appropriate transition equivalent.

Illustration 2-10: Options in tree preservation due to grade change

From: City of Austin

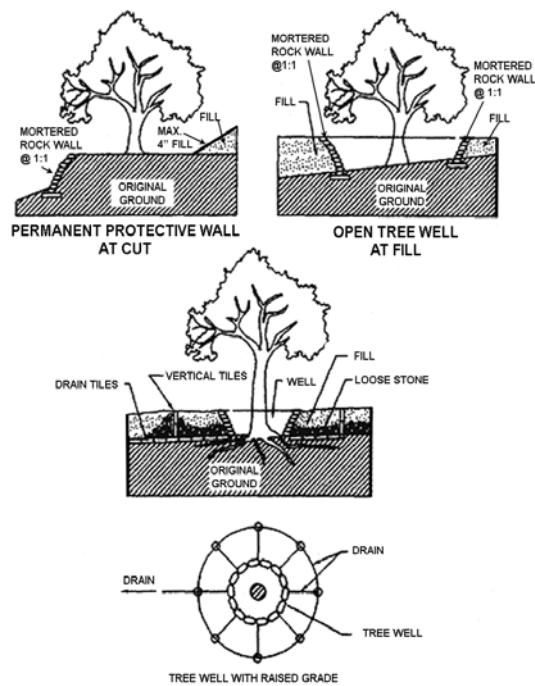

Illustration 2-11: Changing grade around tree trunk by grading or fill. Trees which have too high of a grade during or after construction will lack the root flare.

From: A Guide to Preserving Trees in Development Projects.

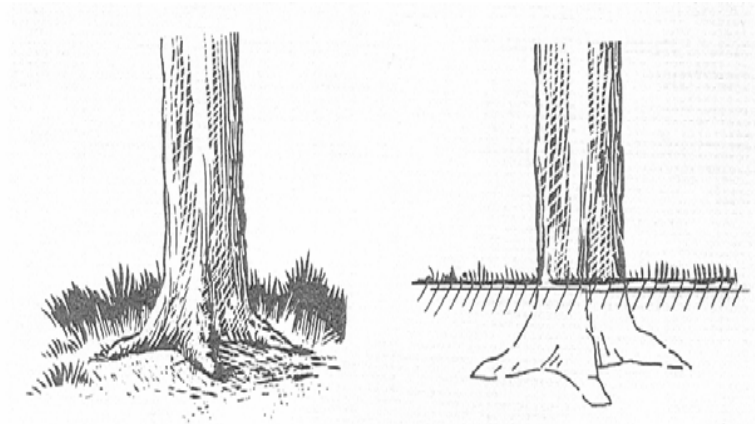
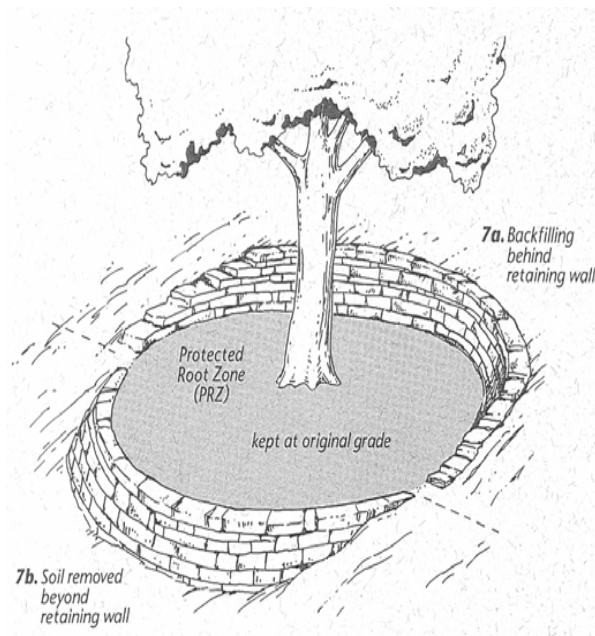

Illustration 2-12: Using retaining walls when natural grade must be raised or lowered.

From: Building Greener Neighborhoods.



2.5.3. Trenching, excavation and equipment use

Normally, trenching is allowed outside of the CRZ. Trenching, excavation or boring activity within the CRZ is restricted to the following activities, conditions and requirements if approved by the Forestry Manager. Mitigating measures shall include prior notification to and direct supervision by the project arborist or landscape architect.

a. Notification. Contractor shall notify the project arborist or landscape architect a minimum of 24 hours in advance of the activity in the CRZ. As noted above, the project arborist or landscape architect must notify the Forestry Manager before any work begins in the CRZ.

b. Root Severance. Roots that are encountered shall be pruned flush with the soil. Backfill root areas with good quality top soil within the same day. If exposed root areas are not backfilled within the same day, cover them with organic material in a manner which reduces soil temperatures and minimizes water loss due to evaporation.

c. Excavation. Any approved excavation, demolition or extraction of material shall be performed with equipment sitting outside the CRZ. Methods permitted are by hand digging, hydraulic or pneumatic air excavation technology.

If excavation or trenching for drainage, utilities, irrigation lines, etc., it is the duty of the contractor to tunnel under any roots 2-inches in diameter and greater.

Prior to excavation for foundation/footings/walls, grading or trenching within the CRZ, roots shall first be severed cleanly 1- foot outside the CRZ and to the depth of the future excavation. The trench must then be hand dug and roots pruned with a saw, narrow trencher with sharp blades or other approved root pruning equipment.

d. Heavy Equipment. Use of backhoes, steel tread tractors or any heavy vehicles within the CRZ is prohibited unless approved by the Forestry Manager. If allowed, a protective root buffer is required.

Structural design. If injurious activity or interference with roots greater than 2-inches will occur within the CRZ, plans shall specify a design of special foundation, footing, walls, concrete slab or pavement designs subject to Forestry Manager approval. Discontinuous foundations such as concrete pier and structural grade beam must maintain natural grade (not to exceed a 4-inch cut), to minimize root loss and allow the tree to use the existing soil.

Basement excavations shall be designed outside the CRZ of all protected trees and shall not be harmful to other mature or neighboring property trees.

Illustration 2-13: Trenching and boring options illustrated.

From: Conserving Wooded Areas in Developing Communities

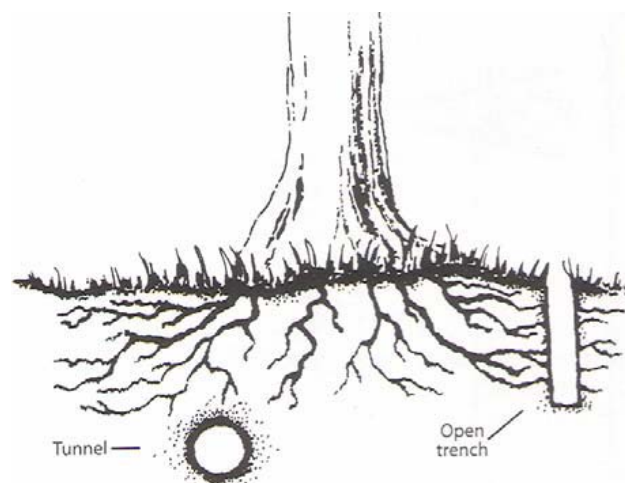

2.5.4. Tunneling and directional drilling

If tunneling or pipe installation has been approved within the CRZ, the trench shall be either cut by hand, air-spade, hydraulic vac-on excavation, or by mechanically boring the tunnel under the roots with a horizontal directional drill and hydraulic or pneumatic air excavation technology. In all cases, install the utility pipe immediately, backfill with soil and soak with water within the same day. Installation of private

utility improvements shall be tunnel bored beneath the tree and roots per Trenching Tunneling and Distance Table in Illustration 2-14.

Emergency utility repairs shall be exempt from the above restriction zones within the CRZ. The Forestry Manager shall be contacted after any such repairs that may result in significant tree damage or removal.

Illustration 2-14: Trenching and boring distances.

TRENCHING DISTANCE



Tree diameter at 54 inches is:

8-19"

20"+

Trenching will be replaced with boring if the CRZ is being encroached.

CRZ

8'-19'

20'+

DEPTH OF TUNNELING



Tree Diameter

9" or less

10-14"

15-19"

More than 19"

Depth of Tunneling

2.5'

3'

3.5'

4.0'

2.5.5. Construction impact mitigation- A mitigation program is required if the approved development will cause drought stress, dust accumulation, or soil compaction to trees that are to be saved. To help reduce impact injury, one or more of the following mitigation measures shall be implemented and supervised by the project arborist or landscape architect as follows:

a. Irrigation program- Irrigate or water weekly with 10- gallons of water per diameter inch within the CRZ. Duration shall be until project completion or when seasonal rainfall begins.

b. Dust control program-. During periods of extended drought, wind or grading, spray wash trunk, limbs and foliage to remove accumulated construction dust.

c. Soil compaction damage- Compaction of the soil is the largest killer of trees on construction sites due to suffocation of roots and ensuing decline of tree health. If compaction occurs to the upper 12-inches of soil within the CRZ by any means, then one or more of the of the following mitigation measures shall be implemented.

i. Type I Mitigation. If an approved paving, hardscape or other compromising material encroaches within the CRZ, an aeration system shall be designed by the project arborist or landscape architect and used within this area (subject to approval by the Forestry Manager).

ii. Type II Mitigation. If inadvertent compaction of the soil has occurred within the CRZ, the soil shall be loosened by one or more of the following methods to promote favorable root conditions: vertical mulching, soil fracturing, coreventing, radial trenching or other method approved by the Forestry Manager.

2.6. DAMAGE TO TREES

2.6.1. Reporting

Any damage or injury to trees shall be reported the same day to the project arborist, landscape architect, job superintendent or Forestry Manager so that mitigation can take place. All mechanical or chemical injury to branches, trunk or roots over 2-inches in diameter shall be reported. In the event of injury, the following mitigation and damage control measures shall apply:

a. Root injury: If trenches are cut and tree roots 2-inches or larger are encountered they must be cleanly cut back to a sound wood lateral root. The end of the root shall be sawed off with a clean cut. All exposed root areas within the CRZ shall be backfilled or covered the same day. Exposed roots may be kept from drying out by temporarily covering the roots and draping layered burlap or carpeting over the upper 3-feet of trench walls. The materials must be kept wet until backfilled to reduce evaporation from the trench walls.

b. Bark or trunk wounding: Current bark tracing and treatment methods shall be performed by a qualified tree care specialist within two days.

c. Scaffold branch or leaf canopy injury: Remove broken or torn branches back to an appropriate branch capable of resuming terminal growth within five days. If leaves are heat scorched from equipment exhaust pipes, consult the project arborist or landscape architect the same day.

2.6.2. Penalty for damage to protected trees

In the event that protected trees or their roots have been damaged, replacement may be required if the Forestry Manager deems that the trees need to be replaced. Damaged trees will be replaced according to Section 10.604 of the Unified Development Code.

2.7. PAVEMENT AND HARDSCAPE CONFLICTS WITH TREE ROOTS

Conflicts may occur when tree roots grow adjacent to paving, foundations, sidewalks or curbs (hardscape). Improper or careless extraction of these elements can cause severe injury to the roots and instability or even death of the trees. The following alternatives must first be considered before root pruning within the CRZ of a protected tree.

2.7.1. Removal and replacement of pavement or sidewalk:

a. Removal of existing pavement over tree roots shall include the following precautions: Break hardscape into manageable pieces with a jackhammer, pick or other approved method and hand load the pieces onto a loader. The loader must remain on undisturbed pavement or off exposed roots. Do not remove base rock that has been exploited by established absorbing roots. Apply untreated wood chips over the exposed area within one hour, then wet the chips and base rock and keep moist until overlay surface is applied.

b. Replacement of pavement or sidewalk: An alternative to the severance of roots greater than 2- inches in diameter should be considered before cutting roots. If an alternative is not feasible, remove the sidewalk and grind roots only as approved by the Forestry Manager. Use wire mesh reinforcement if within 10-feet of the trunk of a protected tree.

2.7.2. Alternative methods to prevent root cutting (Recommended):

The following remedies should be considered before cutting tree roots that may result in tree instability or decline:

a. Grinding a raised sidewalk edge.

b. Ramping the walking surface over the roots or lifted slab with pliable paving.

c. Routing the sidewalk around the tree roots.

d. Inflexible paving or rubberized sections.

e. On private property, new sidewalk or driveway design should offer alternatives to conventional pavement and sidewalk materials. Substitute permeable materials for typical asphalt or concrete overlay, sub-base or footings to consider are: permeable paving materials, interlocking pavers, flexible paving, wooden walkways, porches elevated on posts and brick or flagstone walkways on sand foundations.

2.7.3. Avoiding conflict (Recommended)

Conflicts and associated costs can be avoided or reduced by the following planting practices:

- Plant deep rooted trees that are proven to be non-invasive.
- Over soil that shrinks and swells, install a sidewalk with higher strength that has wire mesh and/or expansion slip joint dowel reinforcement.
- Follow soil loosening planting techniques to promote deep rooting.
- Install root barrier only along the hardscape area of the tree (but allow roots to use open lawn or planter strip areas).

2.7.4. Alternative base course materials (Recommended)

When designing hardscape areas near trees, the project architect or engineer should consider the use of recommended base course material such as an engineered structural soil mix. Structural soil mix will allow a long term cost effective tree and infrastructure compatibility that is particularly suited for the following types of development projects: repair or replacement of sidewalk greater than 40-feet in length; subdivisions with new street tree plantings; planting areas that are designed over structures or parking garages; confined parking lot median and islands or other specialized conditions as warranted.

SECTION 3: TREE REMOVAL, REPLACEMENT, PLANTING, AND MAINTENANCE STANDARDS

3.1. INTRODUCTION

A protected tree may not be removed without City review and approval, except in certain emergencies. The purpose of City review is to verify that the removal is allowed under the Unified Development Code and to prevent unnecessary tree removal. This section discusses conditions for tree removal, replacement of protected trees, planting and pruning of replacement trees, and maintenance.

3.2. TREE REMOVAL

3.2.1. Allowable removal

Tree removal is approved as part of the subdivision and site plan, or building permit process, or in the case of individual trees, through the tree removal permit process. These three processes are defined in the Unified Development Code. *A tree removal permit must be granted, or a site plan or subdivision plat with a tree survey and replacement plan approved, before removing a protected tree regardless of the condition of the tree.*

3.2.2. Protected Tree Removal Permit Application

Tree removal applications are available from the City of Edinburg Forest Manager. The application is required ONLY when a request for tree removal originates with an owner of fully developed land, including a single family house under construction. All other requests for removal of protected trees take place during the subdivision and site development processes as defined in the Unified Development Code. The form can be found in the Appendix D. Additional information may be required by the Forestry Manager. An application for a Protected Tree Removal Permit shall be processed within fifteen (15) working days from the date a complete application is received.

3.3. TREE REPLACEMENT PLAN

Replacement requirements are defined in the Unified Development Code and are limited to protected trees, excluding Champion trees. It is important to note that tree replacements during the site plan process will be addressed in the Unified Development Code.

In selecting trees to be replaced, the types of trees removed will be replaced with the same or similar species. Each replacement tree shall be a minimum of two and one half (2 ½) caliper, a minimum of (10') feet in height from the top of the tree, and a minimum of five (5) feet in spread when planted.

The Tree Replacement Plan will include four elements: 1) a table including the common or Latin name; tree size in caliper inches, height, and spread; tree symbols; quantity; 2) a tree planting plan (may be combined with the Landscape Plan); 3) proper tree planting details including planting hole, tree planting, staking, and mulching; and, 4) notes on proper tree planting as described in section 3.7 of this Manual.

Illustration 3-1 shows the type of information required on a tree replacement plan.

Illustration 3-1: Tree replacement plan Symbol # of trees Species Size



2 trees
Cedar Elm
Ulmus crassifolia
3" caliper
10'-12' high
5' spread



3 trees
Chinquapin Oak
Quercus muehlenbergii
3" caliper
10'-12' high
5' spread



1 tree
Pecan
Carya illinoensis
3" caliper
10'-12' high
5' spread



3 trees
Live Oak
Quercus virginiana
(*fusiformis*)
3" caliper
10'-12' high
5' spread

Required Replacement: 21 inches
Total provided replacement:
7 trees @ 3" cal. = 21 inches
Designated with (R)

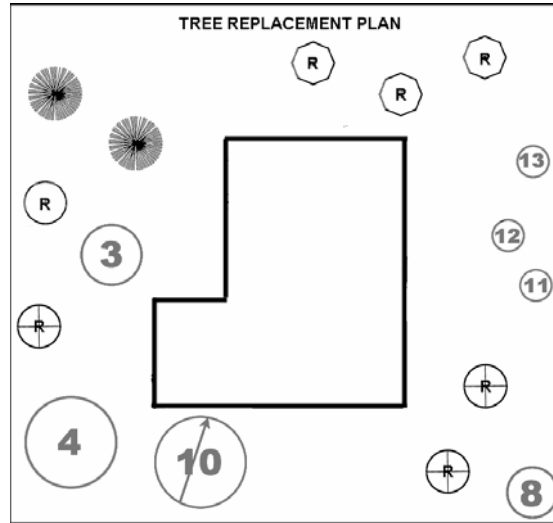

3.4. TREE PLANTING REQUIREMENTS

3.4.1. *Species-*

The replacement trees shall be the same or similar species unless the Forestry Manager determines that another species would be more suitable for the location or if there is a need to promote diversity of species. Factors to be considered include the long term health of the tree in the location and its compatibility with adjacent uses as well as design considerations. If the Forestry Manager deems it necessary to plant species other than those that were removed, the following issues will be considered.

Street trees: Street trees shall be diversified to prevent large scale losses in the event of disease or blight. Each street block shall have at least three (3) genera of street trees, and no more than forty (40) percent of the street streets in the City shall be of the same genus. Exceptions must be approved by the Forestry Manager.

The above restrictions are designed to avoid creating monocultures, or areas of plantings. Creating planting areas of several species creates a more diverse, and therefore more resistant, urban forest. Ficus, Hackberry, Chinese Tallow, Chinaberry, Mulberry, Cottonwood, Poplar, Silver and Maple, and Willow shall not be planted along city streets due to damaging surface roots and the possibility of causing damage to sidewalks, utilities and curbs. These trees also have short lifespans, weak wood, and susceptibility to disease and insects.

With the exceptions noted above, other species shall be chosen from the City of Edinburg approved tree list provided in Appendix B of this Manual.

3.4.2. *Planting distances/spacing requirements:*

a. Minimum distance between newly planted trees

Large sized trees: 50 ft.

Medium sized trees: 30 ft; and,

Small sized trees: 20 feet

b. Minimum distance from any underground utility, water meter boxes, and fire hydrant shall be five feet.

c. Distance from trees to curb, sidewalk, or driveway: Minimum 4 feet.

d. Planting strips should be a minimum of 8 ft wide.

e. Minimum distance from buildings and similar structures:

Large size tree: 30 ft;

Medium size tree: 20 ft; and,

Small size tree: 10 ft.

f. Minimum distance from overhead utility lines. Trees cannot be planted under utility lines. In order to avoid future interference of limbs, planting may take place as follows:

Large trees: 30 feet from line;

Medium trees: 20 feet from line; and

Small trees: 10 feet from line.

g. From curb line of an intersection: 25 feet, which is subject to visibility triangles.

h. Minimum distance from stop or yield signs: 20 feet.

i. Distance from directional traffic sign: 10 feet.

j. Distance from street lights: 25 feet, or 15 feet if narrow growing species is planted.

Tree selection shall take into consideration height clearances. As they grow, trees will need to be pruned to provide pedestrian clearance of at least 8 feet over sidewalks, and vehicular clearance of 14 feet over streets. Variations from the requirements listed above must be approved by the Forestry Manager.

3.5. TREE STOCK AND MATERIALS

3.5.1. Quality

It is the contractor's responsibility to supply tree stock that meets ANSI760.1-1996 and any other standards addressed in this Manual.

- All trees installed within the City of Edinburg shall conform with the *American Standard for Nursery Stock*.
- Trees shall be sound, healthy, vigorous, and free of plant disease and insect pests or their damage.
- Container grown trees shall be grown for at least 8-months in containers in which delivered and shall not be root bound or have girdling roots. The root ball will be moist and the roots will be contained within the container.
- Trees shall not have been topped or headed.
- The tree will have healthy leaves if it is the time of year for trees to have leaves.
- There will be no weeds growing out of the container.

- If the tree is multi-stemmed, the stems will not be squeezing against each other or the trunk of the tree.
- Trees with broken tops, branches, injured trunks, poor structure, low branching, poor vigor, and apparent poor quality shall be rejected and the Forestry Manager has the right to reject them if they do not meet the quality standards.

3.5.2 Container grown/ball and burlapped trees

From April 1-September 30, only container grown trees will be planted. From October 1-March 31, either container grown or ball and burlapped (B&B) trees may be planted.

Recommendation: Regardless, due to the poor soil and high temperatures in our area, it is recommended that container grown trees be used during all times of the year.

3.5.3 Miscellaneous materials-

The following materials shall be used unless otherwise specified:

- Tree stakes. Metal T-posts shall be used.
- Tree Ties. Tree ties shall consist of a plastic chain lock, also called twist brace or other method approved by the Forest Manager which will result in minimal damage to a tree.
- Mulch. All newly planted trees should be mulched with 2-4 inches of organic mulch. Mulch should never be placed against the trunk of a tree. There should be a space of 2-4 inches between the trunk and mulch. Mulch should cover the entire tree planting hole. No volcano mulching is allowed.
- Root Control Barriers. Use along all public sidewalks, and indicate on approved plans and drawings.
- Tree guards. For trees in turf areas requiring regular mowing and/or weed eating, the tree trunk shall be protected with TreeGuard or equivalent.
- Tree grates. Where sidewalk width is less than 8-feet and new trees will be installed in a tree well, metal tree grates may be used and approved by the Forestry Manager. Minimum size grates shall be 4' x 4' unless specified otherwise. All tree grates shall be mounted in frames, frames inset into a concrete foundation within the sidewalk or surface material, and shall be flush with the surrounding surface.

3.6. PLANTING SITE PREPARATION

3.6.1. Soil preparation and conditioning- All debris, wood chips, pavement, concrete and rocks over 2-inches in diameter shall be removed from the planting pit to a minimum of 24-inch depth, unless specified otherwise.

3.6.2. Planter pit preparation

- *Trees in a confined planter pit or sidewalk area:* The planting hole shall be excavated to a minimum of 30-inches deep x the width of the exposed area. Scarify the sides of the pit. Soil beneath the rootball shall be compacted to prevent settling.

- *Trees in all other areas:*

- Mark out a planting area 2 to 3 times wider than the rootball diameter (the wider the better). Loosen this area to about an 8" depth. This will enable your tree to extend a dense mat of tiny roots well out into the soil in the first one to ten weeks in the ground.

- Excavate the hole's width a minimum of two times the diameter of the container, and deep enough to allow the root ball of the container to rest on firm soil with the top of the root ball even with the grade. Scarify the sides and the bottom of the pit.

3.6.3 Drainage

Adequate drainage must be provided to the surrounding soil for the planting of new trees. If the trees are to be planted in impermeable or infertile soil and water infiltration rates are less than two (2) inches an hour, then one of the following drainage systems or other approved measures must be implemented:

- French drain, a minimum of three feet in depth
- Drain tiles or lines beneath the trees
- Auger six drain holes at the bottom perimeter of the planting pit, at a minimum of four (4) inches in diameter, twenty-four (24) inches deep and filled with medium sand or fine gravel

3.6.4. Aeration tubes for trees

- Trees planted in sidewalk planter pits, planting strip, parking islands, or medians shall use 4-inch diameter perforated aeration piping (rigid or flexible), circling the bottom of the planter connected to a 'T' fitting to two riser tubes with grated caps and wrapped with filter fabric. This detail shall be shown on the approved landscape plans.

3.7. PLANTING THE TREE

After the hole has been prepared as described in Section 3.6 above, the tree is ready to be planted.

3.7.1. Container grown tree

Pull the container away from the root ball. Don't pull the tree out by its trunk. Container grown trees often have circling or girdling roots running along the edge of the rootball. If they exist in this area, cut them and spread them apart. Place the root ball in the center of the hole and adjust the tree so it is straight and at the proper level. Make any adjustments prior to filling the hole with dirt.

3.7.2. Ball and burlapped tree

Rest the root ball in the center of the hole, and reshape the hole so the tree will be straight and at the proper level. After adjusting the tree, pull the burlap and any other material away from the sides and top of the root ball. Do not remove the burlap from the bottom. If you adjust or lift the tree after the burlap has been removed you run the risk of damaging the root system.

Illustration 3-2: Tree planting detail graphic

From: City of Round Rock

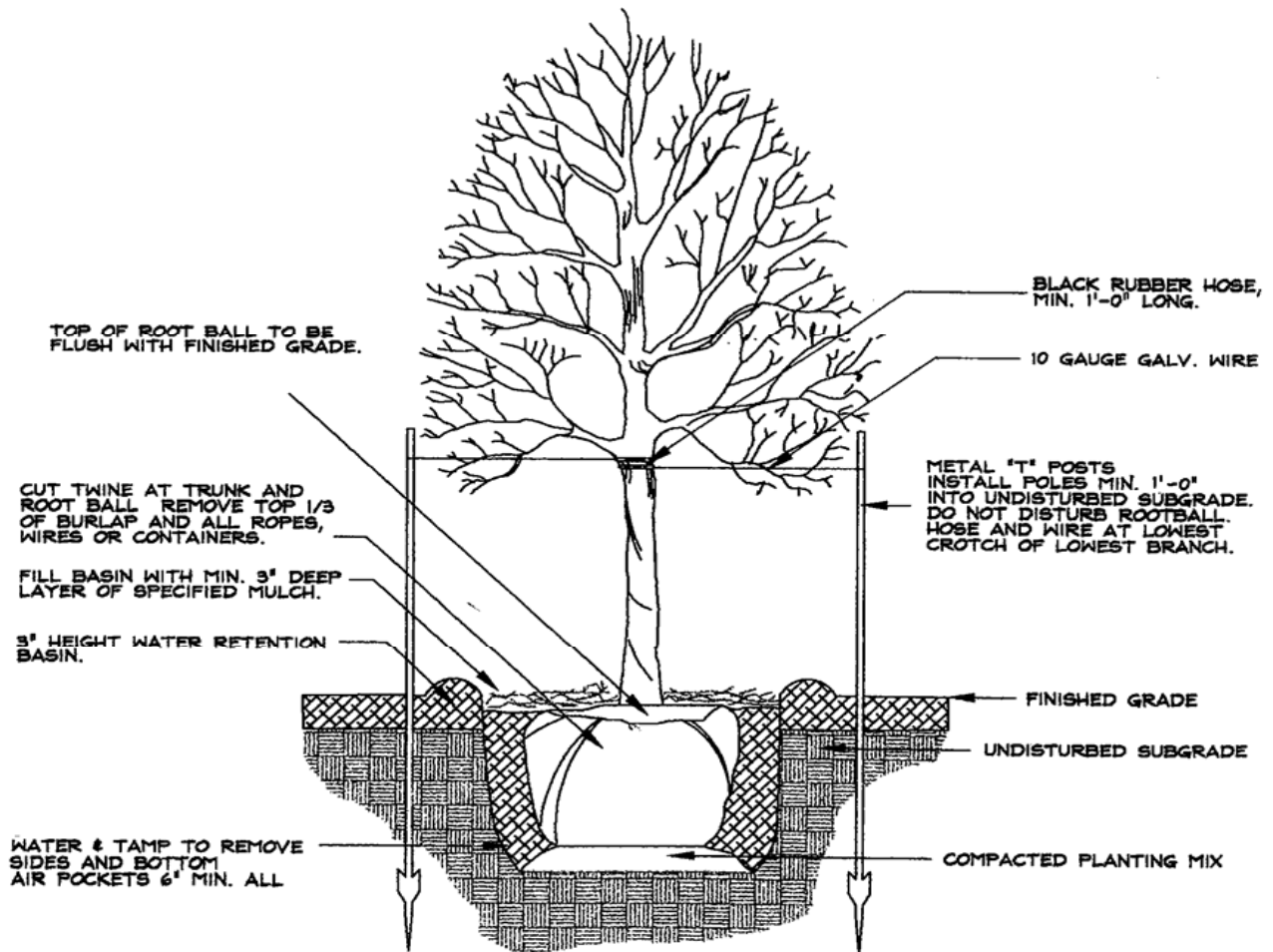

3.7.3. Backfill soil, amended soil

Backfill with the original soil unless the original soil has been removed or the soil is poor. If soil must be amended, consult with a landscape architect or certified arborist in identifying the most appropriate soil mix.

3.7.4. Filling the hole

Fill until the hole is half full. Flood the hole with a slow hose or tamp gently with your foot to firm the soil. Repeat until the hole is full. Do not press too firmly-only firm enough to hold the tree upright. Backfilling with soil and water or gently tamping will remove large air pockets.

3.7.5. Constructing a berm or dam

Construct a small dam or berm three (3) feet in diameter around the tree. The berm should be approximately three (3) inches high.

3.7.6. Mulching

Cover the entire loosened area of soil with 2 to 4 inches of mulch composed of shredded wood or bark in the entire planting area. Mulch will be placed one to two inches away from the trunk of the tree.

3.7.7. Staking or guying

Bamboo stakes, if any, will be removed. Staking or guying is to prevent movement of the lower trunk and root system. Movement of the top is desirable and will strengthen the tree. The stakes will be installed 12-18 inches in undisturbed soil outside of the planting hole. Depending on height and size of the tree, stakes shall be six, eight, or ten feet tall. Trees shall be staked with 3 metal T-posts.

Metal stakes will not rub against tree trunks. Tree ties will be located near the lowest main branch on the tree. Check a staked or guyed tree monthly during the growing season and after storms or strong wind. The system will be snug, but not to the point of making an impression on the stem or trunk. If that happens, loosen the tie or wire around the trunk. Do not stake a tree any longer than necessary. One or two growing seasons is all that is needed.

Illustration 3-2 and 3-3 show the proper staking and guying techniques. In Illustration 3-3 A, trees 3-4 inches in diameter are supported by three stakes. Branches should not rub against the stakes. For trees over four (4) inches, guy wires should be used, with a minimum of three guys. Cable or wire is attached to the tree by running wires through a piece of hose or by using lag hooks on large trees. The guys should be secured to arrowhead-shaped land anchors (C), wooden stakes (D), or deadmen buried in the soil (E).

Illustration 3-3: Staking and Guying Trees
From: Principles and Practice of Planting Trees and Shrubs

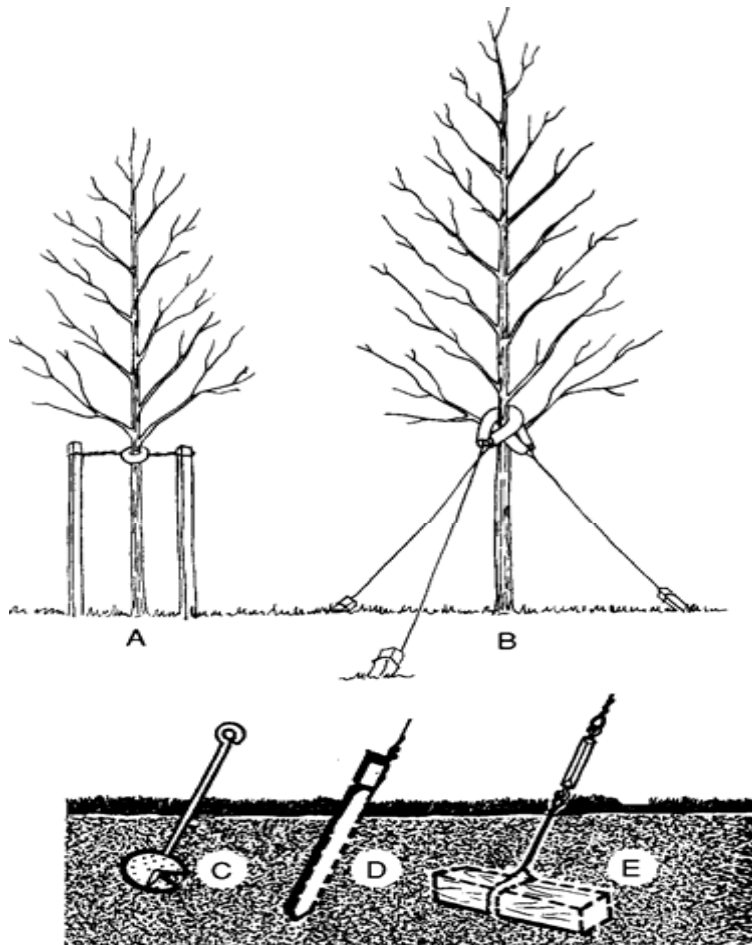

Young trees are pruned to allow for proper growth through the years. If the tree is of high quality, it should need little pruning. It is no longer common practice to automatically trim a certain percentage of limbs from a newly planted tree. The tree needs as much foliage as can be available to assure rapid growth and solid leaf structure. This includes refraining from “limbing up” and topping.

3.8.1. Prohibitions

Topping trees—tree replacement may be required if this is done.

Limbing up trees (the practice of cutting the lowest branches to a desired height)

3.8.2. Pruning guidelines (Recommended)

Scaffolding/ permanent branches. Identify the scaffolding/permanent branches. The lowest permanent branch should have a diameter of one-half or less of the trunk diameter where the branch attaches to the trunk. The vertical spacing of permanent scaffold branches should equal a distance equal to 3% of the tree's eventual height.

Thus, a tree that will be 50 feet tall should have permanent scaffold branches spaced about 18 inches apart along the trunk. Avoid allowing two scaffold branches to arise one above the other on the same side of the tree. Maintain radial balance with branches growing outward in each direction.

3.8.3. Limb removal (Recommended)

The following may be removed.

a. Torn, damaged, dead branches. Remove the branch just outside of the branch collar. See Illustration 2-9.

b. Double Leaders: Maintain a dominant trunk for at least six-eight feet without a major fork. If the trunk divides into two or more relatively equal stems, favor one strong stem and remove the others. Cut one stem back to a lateral branch.

c. Rubbing branches: Eliminate branches that are rubbing or will soon rub against another branch.

d. Crowding: Give each branch room to grow with minimal competition for sunlight. When possible, have major lateral branches evenly spaced eight to ten inches apart along the trunk. If the tree by its nature would lose too much foliage in the process of eliminating crowding, maintain at least half the foliage on branches in the lower 2/3 of the tree.

e. Narrow Branch Angles/Included Bark: Remove one branch if the angle is 40% or narrower or if it appears that the bark from the branch is becoming pinched between the branch and the trunk.

f. Sprouts and Suckers: Remove sprouts and suckers.

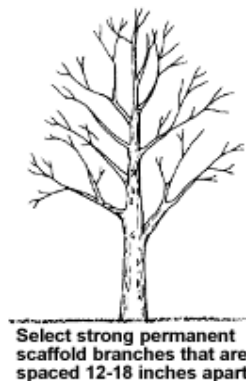

g. Temporary branches: Leave temporary branches that are not competing with permanent, scaffolding branches.

3.9. TRANSPLANTING TREES

Transplanting large trees is difficult, expensive, and requires expertise and equipment. Preapproval from the Forestry Manager and periodic inspections will be required for the transplanting of a protected tree. Such trees will be under warranty as if it is a new tree, and will need to follow replacement requirements should the tree die or severely decline.

When transplanting protected trees eight (8) inches and larger from existing landscapes it is important to select healthy, vigorous trees, dig an appropriate size root ball, select a site that is consistent with the tree's cultural needs, provide a saucer shaped planting hole approximately three times the root ball width, and then protect the root ball, trunk, and crown during lifting, transportation, and storage. The most important and hardest part in tree transplanting is creating and implementing a multi-year aftercare program, providing adequate moisture to the root ball.

When a tree is dug for transplanting, as much as 90% of its root system is left behind, severed in the process of digging for transplanting. The tree has a hard time relying on 5-10 percent of its root system doing the work of the 90 percent that was lost. Until it is well established, the root system will have difficulty supplying enough water to the leaves. This stress impacts vigor of the tree and also exposes the tree to the risk of being vulnerable to pests and diseases, as well as less able to adapt to or withstand drought, extreme cold, and drying winds.

The following issues should assist in providing a successful transplanting. Considering the size of the protected trees being transplanted, a professional arborist is required to assist in the process.

- **Site-** Before transplanting make sure the tree is a good match for the new site.
- **Timing-** Recommended timing for transplanting trees is during the dormant season, when the tree is not trying to support its leafy crown.
- **Health of tree-** Select a tree that is in good health and shape and has no major defects in its trunk branch structure.
- **Success rate-** Different species have different success rates in transplanting. Consult with your certified arborist on the success rate of the tree you want to transplant.
- **Tree size-** Most commonly transplanted trees range in size from 5-15 diameter inches.

Transplanting process-

Digging up the tree-

Dig up a wide root ball with appropriate depth and wrap burlap material with wire and twine to save as much of root ball as you can intact. A rule of thumb for trees over six inches in diameter is that a root ball = 10 inches in diameter for every tree trunk diameter measured at 4 ½ feet above the ground (see Chapter 2 for a discussion on measuring the tree diameter in unusual situations). In other words, a 10 inch tree should have a 100 inch diameter. Likewise, the ball depth should be about 60% of the ball diameter. The same 10 inch tree should have a 60 inch depth.

While smaller trees can be transplanted using a tree spade or other specialty equipment/techniques, larger trees will require mechanical digging equipment and appropriate hoists and heavy equipment for moving the tree.

Transporting the tree-

During transportation the tree crown should always be covered with tarp to protect the tree from drying out and windburn.

After transplanting-

Keep the root ball moist at all times. Anticipate watering three times a week, or in very hot weather every day. Continued watering will be required for several years. **Do not prune newly transplanted trees to reduce crown and compensate for root loss. That will only further weaken the tree.**

Mulch the transplanted tree with 2-4 inches of organic mulch to cover root ball. The process of regenerating a normal root system will take several years, especially for large trees. Immediately after transplanting, the tree will be susceptible to extreme stress. Moisture is a critical factor in new root growth. Compacted soils and soil temperature also impact the growth of roots.

3.10. IRRIGATION PLAN

COMMERCIAL PROPERTIES:

The following requirements are mandatory for all tree replacement plantings. An automatic irrigation system will be installed. Tree irrigation shall not share the same irrigation zone, including valves and circuits, as shrubs and plants due to different watering requirements. A minimum of one (1) bubbler each shall be provided for all newly planted trees. Trees larger than 4 inches in caliper shall have 2 bubblers. Bubblers shall be located between 1-2 feet from the trunk.

All automatic irrigation systems shall be equipped with an electronic controller capable of dual or multiple programming. Controller(s) shall have multiple cycle start capacity and a flexible calendar program, including the capability of being set to water every five days. All automatic irrigation systems shall be equipped with a rain and freeze sensor shut-off device.

The irrigation system must be designed by a landscape architect or licensed irrigator. Please refer to Section 10.505 of the Unified Development Code for other specifications not addressed in this section.

Watering schedule and methods

Newly planted trees will be watered weekly for the first two years. Ten (10) gallons per caliper inch will be applied weekly. During June-September trees will be watered more frequently or at least during each permitted watering day in accordance with the City's Water Conservation Plan. Irrigation plans need to be submitted prior to final inspection.

RESIDENTIAL PROPERTIES (RECOMMENDED):

Trees placed on residential properties are not required to have irrigation systems. When irrigation systems do not exist, trees need to be hand watered.

- Keep the soil moist but not soaked. Water trees at least once a week at the rate of 10 gallons per caliper inch, unless it has rained, and more frequently during hot weather. When the soil is dry below the surface of the mulch, it is time to water. Continue watering weekly during the winter if there is no rain. Continue watering newly planted trees for two years in this manner.

- Water the area within the dripline. A soaker hose is ideal as it can water a greater area at one time and does not need to be moved as often.

3.11 MAINTENANCE

All newly planted trees shall be maintained by the owner. Maintenance practices shall consist of all regular and normal maintenance of trees, including but not limited to irrigation, pruning, and disease control. Plant material that exhibits severe levels of insect or pest infestation, disease and/or damage, shall be appropriately treated, and all dead trees shall be removed and replaced with living trees where required according to the city approved Tree Replacement Plan for the site.

Failure to replace dead or diseased trees within thirty (30) days of written notification to the owner, homeowners association, property owners association, or other responsible party by the City shall constitute a violation of the Unified Development Code and subject to payment of a fee as per Section 10.604. C.

SECTION 4: ADMINISTRATION, INSPECTION, AND ENFORCEMENT

4.1 ADMINISTRATION

The Unified Development Code, Tree Preservation Standards and the standards in this Manual will be administered and updated by the Forestry Manager.

4.2 INSPECTION

4.2.1. Inspection by owner

The project arborist or landscape architect retained by the applicant shall conduct the following required inspections of construction sites containing protected trees. Inspections shall verify that the type of tree protection and/or plantings is consistent with the standards outlined within this Manual. For each required inspection or meeting, a written summary of the changing tree related conditions and actions taken shall be provided to the Forestry Manager.

a. Construction Meeting. Prior to commencement of construction, the applicant or contractor shall conduct a pre-construction meeting to discuss tree protection with the job site superintendent, grading equipment operators, project arborist or landscape architect, and Forestry Manager. At this time all tree protection fencing approved in the permit plans must be installed correctly.

b. Inspection of Rough Grading. The project arborist or landscape architect shall perform an inspection during the course of rough grading adjacent to the CRZ to ensure trees will not be injured by compaction, cut or fill, drainage and trenching, and if required, inspect aeration systems, tree wells, drains and special paving. The contractor shall provide the Forestry Manager at least 48 hours advance notice of such activity.

c. Monthly Inspections. The project arborist or landscape architect shall perform monthly inspections to monitor changing conditions and tree health. The Forestry Manager shall be in receipt of an inspection summary if there are any changes to the approved plans, tree health conditions, or protection measures. If the Forestry Manager is not in receipt of inspection summaries prior to final inspection, he will assume that no change in tree conditions have occurred in the field during construction.

d. Special activity within the Critical Root Zone. Work in this area (CRZ) requires the direct onsite supervision of the project arborist or landscape architect.

e. Landscape Architect Inspection. Prior to the issuing of the certificate of occupancy, the applicant or contractor shall contact the landscape architect to perform an on site inspection of all plant stock, quality of the materials and planting and that the irrigation is functioning consistent with the approved construction plans. The City shall be in receipt of a letter of compliance from the landscape architect prior to scheduling the final inspection, unless otherwise approved.

4.2.2. Inspection by city representative

There are four inspections performed by the Forestry Manager. They include the following:

- a. Site inspection at the site development plan or plat submittal or building permit application.
- b. Tree fencing inspection and other tree preservation measures.

- c. Unscheduled site visits during construction.
- d. Final inspection.

4.3 ENFORCEMENT

The Unified Development Code and the standards in this Manual are enforced by the Forestry Manager.

APPENDIX A: DEFINITIONS

For the purposes of this Manual the following definitions apply. Additional definitions may be found in the Unified Development Code.

Certified Arborist is an individual who has demonstrated knowledge and competency through obtainment of the current International Society of Arboriculture arborist certification, or who is a member of the American Society of Consulting Arborists.

Compaction means compression of the soil structure or texture by any means that creates an upper layer that is impermeable. Compaction is injurious to roots and the health of a tree.

Dangerous tree see Hazardous tree.

Dead Tree means a tree that is dead or that has been damaged beyond repair or is in an advanced state of decline (where an insufficient amount of live tissue, green leaves, limbs or branches, exists to sustain life) and has been determined to be such by a certified arborist. If the tree has been determined to be dead, removal is permitted as defined in the ordinance.

Diameter at Breast Height (DBH) means the tree trunk diameter measured in inches at a height of 4.5 feet (54 inches) above the natural grade or the DBH measurement according to the latest edition of the Guide for Plant Material as published by the Council of Tree and Landscape Appraisers, when the tree trunk branches out at a point lower than 4.5 feet

Disturbance refers to all of the various activities from construction or development that may damage trees.

Excessive Pruning means removing in excess, one-fourth (25 percent) or greater, of the functioning leaf, stem or root area. Pruning in excess of 25 percent is injurious to the tree and is a prohibited act. Excessive pruning typically results in the tree appearing as a 'bonsai,' lion's-tailed', 'lolly-popped' or overly thinned.

Unbalanced Crown. Excessive pruning also includes removal of the leaf or stem area predominantly on one side, topping, or excessive tree canopy or crown raising. Exceptions are when clearance from overhead utilities or public improvements is required or to abate a hazardous condition or a public nuisance.

Roots. Excessive pruning may include the cutting of any root two (2) inches or greater in diameter and/or severing in excess of 25 percent of the roots.

Hazardous Tree refers to a tree that possesses a structural defect which poses an imminent risk if the tree or part of the tree that would fall on someone or something of value (target). Structural defect means any structural weakness or deformity of a tree or its parts. A tree with a structural defect can be verified to be hazardous by a certified arborist and confirmed as such by the Forestry Manager. The Forestry Manager retains discretionary right to approve or amend a hazardous rating, in writing, and recommend any action that may reduce the condition to a less-than significant level of hazard. If the tree has been determined to be hazardous, removal of the tree is permitted as provided for in the Ordinance.

Injury means a wound resulting from any activity, including but not limited to 'excessive pruning', cutting, trenching, excavating, altering the grade, paving or compaction within the tree protection zone of a tree. Injury shall include bruising, scarring, tearing or breaking of roots, bark, trunk, branches or foliage, herbicide or poisoning, or any other action foreseeably leading to the death or permanent damage to tree health.

Landscape Architect means a person who is licensed and registered to engage in the practice of landscape architecture in Texas.

Manual means this Tree Technical Manual: Standards and Specifications.

Partial Tree Survey means a drawing of the proposed preliminary plat or site plan showing the size, location, species and Critical Root Zone of all Champion Trees and trees having a DBH of 8 inches or more; and the size location and species for all protected Trees within easements, rights of way, and a 20 foot strip abutting rights of way. For a site plan, the drawing shall also show all Protected Trees within the limits of construction.

Project Arborist means a certified arborist retained by a property owner or development applicant for the purpose of overseeing on-site activity involving the welfare of the trees to be retained. The project arborist shall be responsible for all reports, appraisals, tree preservation plans, or inspections as required.

Protected Tree shall mean a tree, including a Champion and Heritage Tree that due to its size, species, or unique characteristics, is protected from arbitrary removal.

Protective Tree Fencing means a temporary enclosure erected around a tree to be protected at the boundary of the tree protection zone. The fence serves three primary functions: 1) to keep the foliage crown, branch structure and trunk clear from direct contact and damage by equipment, materials or disturbances; 2) to preserve roots and soil in an intact and noncompacted state; and 3) to identify the tree protection zone in which no soil disturbance is permitted and activities are restricted.

Root Buffer means a temporary layer of material to protect the soil texture and roots. The buffer shall consist of a base course of tree chips or mulch spread over the root area to a minimum of 6-inch depth.

Site Plan means a set of drawings (e.g. preliminary drawings, site plan, grading, demolition, building, utilities, landscape, irrigation, tree survey, etc.) that show existing site conditions and proposed landscape improvements, including trees to be removed, relocated or to be retained. Site plans shall include the following minimum information that may impact trees:

- Surveyed tree location, species, size, dripline area (including trees located on neighboring property that overhang the project site) and protected trees within 30-feet of the project site.
- Paving, concrete, trenching or grade change located within the tree protection zone.
- Existing and proposed utility pathways.
- Surface and subsurface drainage and aeration systems to be used.
- Walls, tree wells, retaining walls and grade change barriers, both temporary and permanent.
- Landscaping, irrigation and lighting within dripline of trees, including all lines, valves, etc.
- Location of other landscaping and significant features.
- All of the final approved site plan sheets shall reference tree protection instructions.

Soil Compaction means the compression of soil particles that may result from the movement of heavy machinery and trucks, storage of construction materials, structures, paving, etc. within the tree protection zone. Soil compaction can result in atrophy of roots and potential death of the tree, with symptoms often taking 3 to 10-years to manifest.

Soil Fracturing means the loosening of hard or compacted soil around a tree by means of a pneumatic soil probe that delivers sudden bursts of air to crack, loosen or expand the soil to improve the root growing environment.

Target is a term used to include people, vehicles, structures or something subject to damage by a tree.

Note: A tree may not be a hazard if a "target" is absent within the falling distance of a tree or its parts (e.g., a defective tree in a non-populated area away from pathways may not be considered a hazard)

Tree Inventory means a drawing showing the tag number, species, size, and approximate location of all existing protected trees.

Tree Survey means a drawing of the proposed preliminary plat or site plan showing the size, location, species, Critical Root Zone of all existing Protected Trees, any protected tree to be removed or transplanted, a table summarizing all protected trees and the total caliper of Protected Trees, in accordance with generally accepted methods such as those provided in the Tree Technical Manual. The Tree survey shall also include non-protected trees on the subject property.

Trenching means any excavation to provide irrigation, install foundations, utility lines, services, pipe, drainage or other property improvements below grade. Trenching within the CRZ is injurious to roots and tree health and is prohibited, unless approved. If trenching is approved within the CRZ, it must be in accordance with instructions and table outlined in this Manual.

Verification of Tree Protection means the project arborist shall verify, in writing, that all preconstruction conditions have been met (tree fencing, erosion control, pruning, etc.) and are in place. An initial inspection of protective fencing and written verification must be submitted to the Forestry Manager prior to demolition, grading or building permit issuance.

Vertical Mulching means auguring, hydraulic or air excavation of vertical holes within a tree's root zone to loosen and aerate the soil, typically to mitigate compacted soil. Holes are typically penetrated 4- to 6-feet on center, 2- to 3-feet deep, 2- to 6-inches in diameter and backfilled with either perlite, vermiculite, peat moss or a mixture thereof.

(APPENDIX B)

City of Edinburg Native (Permitted) Plant List																		
Scientific Name	Family	Common Name(s)	Aquatic	Moist Soils	Riparian	Upland	Full Shade	Shade/Sun	Full Sun	Attracts Wildlife (B=Bird Bu=Butterfly Be=Bee H=Hummingbirds)	Mature Height	Mature Width	Growth Rate (Fast, Medium, Slow)	Spacing	Lifespan: P= Perennial, A=Annual, D=deciduous E=Evergreen, SE=some evergreen	Blooming Period	Bloom Color	COMMENTS
Large Trees																		
<i>Acacia wrightii</i>	Fabaceae	Wright's Acacia				X	X	X		Be	30'	20'	Medium	20'	P, D	Spring	White	Recurved spines; heat & drought tolerant
<i>Celtis laevigata</i>	Ulmaceae	Sugar Hackberry		X	X	X	X	X		Bi	45'	50'	Fast	50'	P, D	Spring	Greenish	Fast growing shade tree; small fruit is extremely valuable for birds; limbs fairly brittle; drops fine, sticky sap, which is messy
<i>Ehretia anacua</i>	Boraginaceae	Anacua				X	X	X		Bi	45'	50'	Slow	50'	P, D	Jun-Oct	White	Fragrant, showy clusters of small, white flowers produce large quantities of fruit valuable to wildlife; fruit drop can be messy; good shade tree
<i>Fraxinus berlandieriana</i>	Oleaceae	Mexican Ash, Fresno		X	X			X	X	Bi	50'	75'	Medium	75'	P, D	Spring	Greenish	Large, spreading tree that requires regular watering to reach full potential; papery, winged fruits on female trees only
<i>Leucaena pulverulenta</i>	Fabaceae	Tepeguaje, Lead Tree				X			X	Be	40'	50'	Fast	50'	P, D	Spring Summer	White	Very fast growing tree, but relatively short lived; limbs brittle and break easily, and subject to girdling beetles
<i>Pithecellobium ebano</i>	Fabaceae	Texas Ebony, Ebano			X	X			X	Bi, Be	45'	50'	Slow	50'	P, SE	Summer	Yellowish or cream	Dense shade tree provides important nest sites for birds; thorny; produces masses of cream-colored flowers after rains; fruit a woody pod
<i>Prosopis glandulosa</i>	Fabaceae	Mesquite				X			X	Be	50'	50'	Medium	50'	P, D	Summer	White	Important, open shade tree; old, mature trees are majestic, with interesting shapes; sweet fruit valuable to wildlife
<i>Quercus virginiana</i>	Fagaceae	Live Oak, Encino				X			X	Bi	50'	80-100'	Medium	80-100'	P, E	Spring	Yellow catkins	Dense shade tree provides important nest sites and cover for birds; some years produces masses of relatively small acorns; will produce shoots from roots
<i>Sabal mexicana</i>	Arecaceae	Sabal Palm		X	X			X	X	Bi	45'	20'	Slow	20'	P, E	Spring	White or creamy	Our only native palm; frond bases provide cover for wildlife
<i>Salix nigra</i>	Salicaceae	Willow, Black Willow, Sauz		X	X			X	X	Bi, Be	55'	30'	Fast	30'	P, D	Spring	Creamy yellow	A tree of resaca, pond, and lake edges; requires plenty of moisture; not thorny
<i>Sapindus saponaria</i>	Sapindaceae	Western Soapberry				X			X	Bi, Bu	50'	30'	Fast	30'	P, D	Spring	Creamy yellow	Spineless tree produces large amounts of yellow-orange fruits that can be self-seeding and messy if falling on sidewalk or other surface
<i>Taxodium mucronatum</i>	Taxodiaceae	Montezuma Bald Cypress		X	X				X	Bi	80'	50'	Slow	50'	P, E-SE	Winter	Brownish	A tree of resaca, pond, lake, and river banks; requires plenty of moisture; not thorny; fruit a small cone
<i>Ulmus crassifolia</i>	Ulmaceae	Cedar Elm		X	X	X			X	Bi	75'	50'	Medium	50'	P, SE	Summer-Fall	Red to green	Tall shade tree that provides nest sites & cover for birds; does better w/ plenty of moisture; susceptible to Dutch Elm Disease
Medium Tree																		

Scientific Name	Family	Common Name(s)	Aquatic	Moist Soils	Riparian	Upland	Full Shade	Shade/Sun	Full Sun	Attracts Wildlife (B=Bird, Bu=Butterfly, Be=Bee, F=Hummingbirds)	Mature Height	Mature Width	Growth Rate (Fast, Medium, Slow)	Spacing	Lifespan: P= Perennial, A=Annual, D=Deciduous E=Evergreen, SE=semi-evergreen	Blooming Period	Bloom Color	COMMENTS
<i>Acacia smallii</i>	Fabaceae	Huisache		X	X	X			X	Bi, Bu, Be	18'	20'	Fast	20'	P, D	Feb-Mar	Yellowish-gold	Fast growing, bushy, thorny tree; does better in moist soil or near water, beautiful clusters of fragrant flowers; produces woody pod; limbs subject to being cut by girdling beetles
<i>Bumelia celastrina</i>	Sapotaceae	Coma			X	X	X	X		Bi	25'	15'	Medium	15'	P, E	Summer	Whitish	Dark green foliage; inconspicuous flowers very fragrant; purple-black fruit valuable for birds and other wildlife
<i>Cordia boissieri</i>	Boraginaceae	Wild Olive				X			X	Bi, Bu	15'	10'	Slow	10'	P, E, SE	Spring-Summer	White with yellow throats	Produces very attractive white flowers during most of the year; fruit drop can be messy
<i>Havardia pallens</i>	Fabaceae	Tenaza				X	X	X		Be	15'	15'	Medium	15'	P, E	Spring-Summer	White	A slender, thorny tree with pale bark, sometimes with multiple trunks
<i>Parkinsonia aculeata</i>	Fabaceae	Retama		X	X			X	X	Be, Bu	25'	20'	Medium	20'	P, D	Spring	Yellow	An open-canopied, thorny, green-barked tree that produces yellow flowers in the spring; requires moist soils for best growth; branches brittle
Small Tree																		
<i>Caesalpinia mexicana</i>	Fabaceae	Mexican Caesalpinia						X	X	Bu	18'	12'	Fast	12'	P, E	Spring-Summer	Bright yellow with a touch of red	Slender tree with very attractive flowers
<i>Diospyros texana</i>	Ebenaceae	Texas Persimmon; Chapote				X	X	X		Bi	18'	15'	Medium	15'	P, D	Spring	Green to white-green	Smooth barked, spineless tree, produces a plum-sized, multi-seeded fruit on female trees only
<i>Guaiacum angustifolium</i>	Zygophyllaceae	Guayacan				X	X	X		Bi, Bu, Be	20'	15'	Slow	15'	P, E	Mar-Apr	Violet or purple	Very hard wooded, spineless, small tree or shrub; provides good cover for wildlife
<i>Solanum erianthum</i>	Solanaceae	Potato Tree			X		X	X		Bi	8'	8'	Fast	8'	P	Apr-Oct	White	Rare, fast-growing small tree or shrub; marble-sized, yellowish fruit eaten by birds
Shrub																		
<i>Acacia rigidula</i>	Fabaceae	Black Brush				X			X	Be	9'	5'	Slow	5'	D	Spring	White	Thorny shrub produces good cover for wildlife
<i>Adelia vaseyi</i>	Euphorbiaceae	Vasey's Adelia		X		X		X	X	Bu	9'	4'	Medium	4'	P	Spring	Whitish	Rare shrub with many erect branches from the base; small fruit on female trees only
<i>Agave americana</i>	Amaryllidaceae	Century Plant				X			X	Bi	6'	1-5'	Slow	1-5'	E	Summer	Greenish-white	Flower stalk to 21' tall. Plant dies but creates offshoots; good in xeriscape
<i>Aloysia gratissima</i>	Verbenaceae	Whitebrush, Beebrush				X			X	Bi, Bu, Be	9'	6'	Medium		P	Spring-Fall	White	Thornless shrub produces a spike of very fragrant, small white flowers
<i>Amyris madrensis</i>	Rutaceae	Mexican Amyris, Mountain Touchwood				X	X	X	X	Bi, Be	6-10'	6-8'	Medium	8-10'	P, E	Spring-Fall	Green or white	Spineless, evergreen shrub, member of citrus family, with dark green foliage, fragrant flowers and black fruit
<i>Amyris texana</i>	Rutaceae	Chapotillo				X	X	X		Bi	6-10'	6-8'	Medium	8-10'	E	Spring-Fall	Greenish-white	Spineless, evergreen shrub, member of citrus family, with dark green foliage, fragrant flowers and black fruit; best in well drained soil, drought tolerant
<i>Buddleja sessiliflora</i>	Loganiaceae	Butterfly Bush				X	X	X		Bu	6'	5'	Fast	5'	P, E	Winter-Spring	Yellow	Spineless, dense shrub attractive to butterflies; produces tight clusters of small, inconspicuous flowers
<i>Capsicum annuum</i>	Solanaceae	Chile Piquin, Chilipiquin, Bird Pepper		X	X	X	X	X	X	Bi	4-5'	3-4'	Fast	3-4'	P	Yearround	White	Mature fruit red, small, edible, very hot; medium water; volunteers aggressively from seed; excellent for birds
<i>Castela erecta</i>	Simaroubaceae	Goat Bush, Chaparro				X	X	X		Bi	6'	6'	Slow	6'	P, E	Spring	Reddish	Very thorny shrubs with small leaves and flowers; will form a good, impenetrable hedge

Scientific Name	Family	Common Name(s)	Aquatic	Moist Soils	Riparian	Upland	Full Shade	Shade/Sun	Full Sun	Attracts Wildlife (B=Bird Bu=Butterfly Be=Bee H=Hummingbirds)	Mature Height	Mature Width	Growth Rate (F=Fast, Medium, Slow)	Spacing	Lifespan: P= Perennial, A=Annual, D=Deciduous E=Evergreen, SE=Semievergreen	Blooming Period	Bloom Color	COMMENTS
<i>Celtis pallida</i>	Ulmaceae	Granjeno, Spiny Hackberry				X			X	Bi, Bu	8-15'	12'	Medium	12'	D	Spring	Greenish yellow	Spiny shrub with pea-sized, orange fruit at maturity; valuable food for birds and other wildlife; larval food for Snout butterflies; heat & drought tolerant
<i>Chiococca alba</i>	Rubiaceae	Snow Berry			X		X	X		Bi, Bu, Be	6-10'	6-10'	Fast	6'	E	All year	White or yellow	Spineless, clambering shrub will grow on trellis, normally found in moist, humid woodlands; rare; fruit a pea-sized white, waxy berry
<i>Colubrina texensis</i>	Rhamnaceae	Hogplum				X			X	Bi	6-8'	8'	Medium	8'	D	Spring	Greenish-yellow	Seeds poisonous to sheep(???). Heat tolerance high.
<i>Condalia hookeri</i>	Rhamnaceae	Brasil				X			X	Bi	15'	15'	Slow	15'	E	Spring	Greenish	Normally a shrub, but old specimens can be fairly substantial trees; small purple-black fruit valuable to birds
<i>Coursetia axillaris</i>	Fabaceae	Baby Bonnets				X			X	Be	6'	5'	Medium	5'	P, E		Pinkish	Relatively rare and attractive, spineless, evergreen shrub; requires well drained soil
<i>Croton capitatus</i>	Euphorbiaceae	Wooly Croton								Bi, Bu, Be	5'	4'	Medium	4'	A	Spring-Fall	Whitish	Relatively small, open shrub generally lasting only one growing season; leaves aromatic; black seeds eaten by birds
<i>Croton incanus</i>	Euphorbiaceae	Torrey's Croton								Bi, Bu, Be	4'	3'	Medium	3'	A	Spring-Fall	Whitish	Relatively small, open shrub generally lasting only one growing season; leaves aromatic; black seeds eaten by birds
<i>Erythrina herbacea</i>	Fabaceae	Coral Bean			X	X	X	X		H	10'	5-10'	Medium	8'	D	Spring	Scarlet red	Open shrub produces red flowers attractive to hummingbirds; red seed poisonous
<i>Eysenhardtia texama</i>	Fabaceae	Kidney Wood				X			X	Bi, Bu, Be	9'	6'	Slow	6'	P		White	Thornless shrub produces a spike of very fragrant, small white flowers
<i>Eupatorium azureum</i>	Asteraceae	Blue Boneset			X	X		X		Bu	3'	6-8'	Fast	6-8'	P, E	Winter-Spring	Blue	Sprawling, thornless, weak-limbed shrub; produces clusters of blue flowers attractive to butterflies
<i>Eupatorium betonicifolia</i>	Asteraceae	Betony Mistflower		X	X	X		X	X	Bu	3'	4-5'	Fast	4-5'	P, E	Fall-Spring	Blue	Sprawling, thornless, weak-limbed shrub; produces clusters of blue flowers; normally found near the coast; however, widely planted to attract butterflies
<i>Eupatorium odoratum</i>	Asteraceae	Crucita			X	X		X	X	Bu	3'	6-8'	Fast	6-8'	P, E	Fall-Winter	Blue	Sprawling, thornless, weak-limbed shrub; produces clusters of blue flowers attractive to butterflies
<i>Karwinskia humboldtiana</i>	Rhamnaceae	Coyotillo				X			X	Bi	6'	6-8'	Slow	6-8'	E	Summer-Fall	Greenish-white	Attractive and hardy evergreen shrub; fruits toxic to humans
<i>Lantana horrida</i>	Verbenaceae	Texas Lantana				X		X	X	Bi, Bu, Be	4'	5-6'	Medium	5-6'		Mar-Dec	Yellow,Orange,Red	Attractive flowers; drought & heat tolerant; low water requirements; suited for xeriscaping; strongly scented foliage is found unpleasant by some; seeds are poisonous; leaves may cause skin irritation
<i>Lantana macropoda</i>	Verbenaceae	Desert Lantana				X		X	X	Bi, Bu, Be	3'	5-6'	Medium	5-6'	P	All year	White	More drought tolerant than Texas Lantana; produces attractive clusters of small white flowers
<i>Leucophyllum frutescens</i>	Scrophulariaceae	Cenizo; Texas Sage				X			X	Bi, Bu, Be	6'	5'	Medium	5'	P	Summer, Fall	Purple, Pink, White	Thornless shrub with green-gray leaves; grows best in well-drained, acid soil; produces very showy displays of flowers after rains; heat and drought tolerant; do not fertilize
<i>Lippia graveolens</i>	Verbenaceae	Mexican Oregano				X			X	Bi, Bu, Be	6'	6'	Medium	6'	P	Spring-Summer	White	Thornless shrub that is very drought tolerant; leaves have aromatic fragrance of oregano

Scientific Name	Family	Common Name(s)	Aquatic	Moist Soils	Riparian	Upland	Full Shade	Shade/Sun	Full Sun	Attracts Wildlife (B=Bird Bu=Butterfly Be=Bee H=Hummingbirds)	Mature Height	Mature Width	Growth Rate (F=Fast, Medium, Slow)	Spacing	Lifespan: P= Perennial, A=Annual, D=Deciduous E=Evergreen, SE=semi-evergreen	Blooming Period	Bloom Color	COMMENTS	
<i>Malvaviscus arboreus</i>	Malvaceae	Turk's Cap		X	X		X	X		Bi, Bu, H	5'	5'	Fast	5'	P	All year	Bright red	A native hibiscus; requires moisture; bright red flowers attract hummingbirds	
<i>Malpighia glabra</i>	Malpighiaceae	Barbados Cherry			X	X	X	X		Bi, Bu	4-6'	4-5'	Medium	4-5'	P	All year	Purple	This spineless shrub is heat and drought tolerant, with glossy leaves; forms a good hedge; red fruit eaten by birds	
<i>Melochia tomentosa</i>	Sterculiaceae	Wooly Pyramid Bush				X			X	Bu	6'	6'	Fast	6'	P	Spring -Fall	Purple	Thornless shrub very attractive to butterflies	
<i>Phaulothamnus spinescens</i>	Phytolaccaceae	Snake Eyes				X	X	X		Bi	8'	8'	Medium	8'	D	Spring	Pale	Spiney, dense shrub; male and female flowers on separate plants; high heat tolerance; black seed can be seen in translucent fruit, giving it the appearance of an eye, thus the common name	
<i>Salvia ballotaeflora</i>	Lamiaceae	Blue Sage			X	X	X			Bi, Bu, Be	5'	4-5'	Medium	4-5'	A	Summer	Blue	Thornless shrub producing blue flowers; member of the mint family	
<i>Sophora secundiflora</i>	Fabaceae	Texas Mountain Laurel; Mescal Bean				X	X	X		Bi, Bu	12'	10'	Slow	10'	P, E	Spring	Purple, Lavender	Thornless plant with deep green foliage; flowers fragrant; seeds poisonous	
<i>Sophora tomentosa</i>	Fabaceae	Yellow Sophora				X		X		Bi, Bu, Be	3-6'	6'	Medium	6'	P, D	Spring	Yellow	Normally found in sandy soils near coast; provides cover in wildlife plantings	
<i>Trixis inula</i>	Asteraceae	Mexican Trixis			X	X	X	X		Bu	3-6'	5-6'	Medium	5-6'	P	Fall-Spring	Bright Yellow	Thornless, weak-limbed shrub produces yellow flower clusters attractive to butterflies	
<i>Viguiera stenoloba</i>	Asteraceae	Skeletonbush, Golden-eye Daisy				X		X		Bu	3-6'	4-5'	Fast	5'	P	Yearround	Yellow	Spineless shrub, heat and drought tolerant; requires well drained soil	
<i>Yucca treculeana</i>	Liliaceae	Yucca, Spanish Dagger				X	X	X		Bi	6-12'		Slow		P	Late winter to early spring	Creamy white	Produces showy, white-flowered stalks; ends of leaves are dangerously sharp-pointed; good in xeriscape	
<i>Zanthoxylum fagara</i>	Rutaceae	Colima				X	X	X		Bi, Bu	5-20'	8-10'	Slow	8-10'	E	Spring	Yellowish-green	Open shrub with recurved spines that will make an impenetrable hedge; provides good cover; birds eat seeds	
<i>Ziziphus obtusifolia</i>	Rhamnaceae	Lotebush				X	X	X		Bi, Bu	8-10'	10-12'	Slow	10-12'	D	Spring	Greenish-white	Thorny, open shrub	
Herbaceous																			
<i>Abronia ameliae</i>	Nyctaginaceae	Amelia's Sand Verbena				X		X		Bu, Be	12"	14"	Fast	14"	A	Spring	Lavender-purple	Beautiful heads of lavender-purple flowers; prefers sandy soil	
<i>Asclepias spp.</i>	Asclepiadaceae	Milkweed				X	X	X		Bu	2-3'	1-2'	Fast	2-3'	P	Summer	White or Red and Yellow	Numerous species of milkweeds are important to Monarchs, Queens and other butterflies; the red and yellow flowered species is most attractive to humans	
<i>Commelina erecta</i>	Commelinaceae	Widow's Tears, Dayflower		X			X	X		Bi	1-2'	Mat-forming	Fast	1-2'	P	Spring-Summer	Blue	Beautiful displays of blue flowers; spreads in the garden and lawns; older foliage needs to be trimmed	
<i>Coreopsis tinctoria</i>	Asteraceae	Coreopsis		X	X	X	X	X		Bu, Be	3-4.5'	6-12"	Fast		P	Summer	Yellow & red	Produces lovely displays of flowers, but has a relatively high water requirement	
<i>Dicliptera vahliana</i>	Acanthaceae	Dicliptera		X	X	X	X	X		Bu	2'	1.5'	Fast		A	Spring	Red	Rare; produces red, tubular flowers; can spread quickly and take over an area	
<i>Dyssodia tenuiloba</i>	Asteraceae	Tiny Tim				X		X		Bu, Be	6"	6-8"	Fast	8-10"	A	Spring	Yellow	Low-growing plant produces brilliant displays of yellow flowers; heat and drought tolerant; self-seeds	
<i>Gaillardia pulchella</i>	Asteraceae	Indian Blanket				X	X	X		Bu	1-2'	1-2'	Fast	1-2'	A	Spring-Fall	Red & yellow	One of the more common and easily recognized roadside wildflowers of Texas; produces beautiful, self-seeding flowers	

Scientific Name	Family	Common Name(s)	Aquatic	Moist Soils	Riparian	Upland	Full Shade	Shade/Sun	Full Sun	Attracts Wildlife (B=Bird Bu=Butterfly Be=Bee H=Hummingbirds)	Mature Height	Mature Width	Growth Rate (Fast, Medium, Slow)	Spacing	Lifespan: P= Perennial, A=Annual, D=Deciduous E=Evergreen, S=Semievergreen	Blooming Period	Bloom Color	COMMENTS	
<i>Heliotropium spp.</i>	Boraginaceae	Heliotrope		X		X		X	X	Bu	1.5-2'	1-2'	Fast	1-2'	A	Spring-Fall	White to purplish	Generally low-growing, and often do well in poor or disturbed soils; some species are very attractive to butterflies	
<i>Hibiscus cardiophyllus</i>	Malvaceae	Tulipan del Monte				X		X		Bi, Bu	1-3'	1-2'	Medium		P	Spring-Fall	Red	A drought tolerant native hibiscus producing brilliant red flowers	
<i>Justicia runyonii</i>	Acanthaceae	Runyon's Water-Willow		X	X		X	X	X	Bu	2-3'		Fast		P	Spring-Fall	Lavender	Rare native of moist, clay soils, produces tubular lavender flowers, with darker specks in the throat	
<i>Lupinus texensis</i>	Fabaceae	Texas Bluebonnet				X			X	Be, Bu	12"	8"	Fast	8"	A	Spring	Blue	State flower of Texas; seeds should be planted in the fall, the basal rosette will grow in the fall and over-winter, and the plants will flower in the spring	
<i>Manfreda spp.</i>	Amaryllidaceae	Huaco				X		X	X	Bu	2-3"	12"	Slow	14"	P	Spring, and after rains	Greenish	Succulent ground cover, the leaves form a basal rosette	
<i>Marsilea macropoda</i>	Marsileaceae	Water Fern; Water Clover	X	X	X			X	X		6"	Mat-forming	Fast		P	Spring-Fall	Does not produce flowers	Pond edges & wetlands; requires water	
<i>Nymphaea elegans</i>	Nymphaeaceae	Blue Water Lily	X								8-12"	10"	Fast	10"	P	Spring	Blue	This is a wetlands species that requires standing, shallow water	
<i>Phyla spp.</i>	Verbenaceae	Frog Fruit				X		X	X	Bi, Bu, Be	6"	Mat-forming	Fast	8-12"	P	Yearround	White tinged with lavender	semi-evergreen, drought tolerant ground cover	
<i>Plumbago scandens</i>	Plumbaginaceae	Plumbago, Hierba de Alacran		X		X	X	X	X	Bu	3'	Sprawling	Fast	4-5'	P	Spring-Fall	White	a.k.a. "doctorbush" "summer snow"; toxic to goats	
<i>Ratibida columnaris</i>	Asteraceae	Mexican Hat				X		X	X	Bi, Bu, Be	2-3'		Fast	15-18"	A	Spring-Fall	Red and yellow	semi-evergreen; heat & drought tolerant	
<i>Rivina humilis</i>	Phytolaccaceae	Pigeon Berry; Coralito			X	X	X	X	X	Bi, Bu, Be	1-2'	1-2'	Fast	2'	A	Yearround	White	Normally a plant of shaded woodlands, it produces a spray of small, delicate flowers that form small, red fruits consumed by wildlife	
<i>Ruellia spp.</i>	Acanthaceae	Wild Petunia; Mexican Petunia		X	X	X		X	X	Bu	1.5'	1'	Fast	15-18"	A	Spring-Fall	Purple	Heat & drought tolerant	
<i>Sagittaria longiloba</i>	Alismataceae	Arrowhead	X	X							2-3'	1'	Fast	1-2'	P	Spring-Fall	White	A relatively common wetland native	
<i>Salvia coccinea</i>	Lamiaceae	Tropical Sage; Scarlet Sage			X	X	X	X	X	Bi, Bu, Be	1.5-4'	6-10'	Fast	6-9'	A	Summer-Fall	Red	This member of the mint family produces showy, brilliant red flowers that attract hummingbirds	
<i>Solanum americanum</i>	Solanaceae	American Nightshade, Black Nightshade		X	X	X		X	X	Bi	3-4'	3-4'	Fast	4'	A	Spring-Fall	White	A robust, shrub-like plant that produces purple-black fruits from small, white flowers; birds very attracted to fruit	
<i>Stachys drummondii</i>	Lamiaceae	Pink Mint			X	X	X	X	X	Bu, Be	18"	6"	Fast	6"	A	Spring	Pink	Produces dense clusters of plants and flowers, with fragrant leaves; self-seeds, to produce a new stand the following spring	
<i>Verbena spp.</i>	Verbenaceae	Verbena; Vervain				X		X	X	Bu	0.5-1'	1-1.5'	Fast	6-12"	A	Spring-Fall	Purple, Blue	Some species produce a thin, upright flower stalk, while other species produce a flattened, dense flower cluster; drought tolerant	
<i>Verbesina enceloides</i>	Asteraceae	Cowpen Daisy				X		X	X	Bi, Bu, Be	2'	0.5-2'	Fast	18-36"	A	Spring-Fall	Yellow	Common wildflower, with medium water requirement; grows in wide variety of soils; self-seeding	
<i>Wedelia hispida</i>	Asteraceae	Wedelia, Orange Zexmenia				X		X	X	Bu	2-3'	3'	Medium	3'	P	Spring-Fall	Yellow	Evergreen mounding ground cover; heat and drought tolerant	
Vine																			
<i>Cardiopsemum spp.</i>	Sapindaceae	Baloon Vine			X	X		X	X	Bi, Be, Bu		Twining vine	Fast		P	Spring	Cream	Climbing vine	
<i>Passiflora incarnata</i>	Passifloraceae	Passion-Flower Vine			X	X		X	X	Bu	12'	Twining vine	Fast		D	Spring-Fall	Lavender	Texas native. Perennial	

Scientific Name	Family	Common Name(s)	Aquatic	Moist Soils	Riparian	Upland	Full Shade	Shade/Sun	Full Sun	Attracts Wildlife (B=Bird Bu=Butterfly Be=Bee H=hummingbirds)	Mature Height	Mature Width	Growth Rate (Fast, Medium, Slow)	Spacing	Lifespan: P= Perennial, A=Annual, D=deciduous E=Evergreen SE=semi-evergreen	Blooming Period	Bloom Color	COMMENTS	
<i>Passiflora foetida</i>	Passifloraceae	Passion-Flower Vine					X			Bu		Twining vine	Fast						
<i>Pisonia aculeata</i>	Nyctaginaceae	Devil's Claw			X	X	X	X		Be, Bu	25'	Clambering, woody vine- like plant	Medium	20"	P	Spring	Cream	A rare, woody, perennial plant with with recurved spines; growth is vine-like; would form a good cover for a trellis	

(APPENDIX B)

City of Edinburg Non-Native Plant List

Scientific Name	Family	Common Name(s)	Aquatic	Moist Soils	Riparian	Upland	Full Shade	Shade/Sun	Full Sun	Attracts Wildlife (B=Bird Bu=Butterfly Be=Bee P=hummingbirds)	Mature Height	Mature Width	Growth Rate (Fast, Medium, Slow)	Spacing	Lifespan: P= Perennial, A=Annual, D=deciduous E=Evergreen SE=semi-evergreen	Blooming Period	Bloom Color	COMMENTS	
<i>Jacaranda mimosifolia</i>	Begoniaceae	Blue Jacaranda		x					x	Bu	20-25'	15'	F		P, D	Spring	Lavendar	Clusters of fragrant blooms, native to So. America, requires enriched, sandy soils, unsuited for small lots.	
<i>Koelreuteria paniculata</i>	Sapindaceae	Goldenrain Tree			x				x	Bu	30-40'	30-35'	M	30'	P	Late summer	Golden yellow	Clusters of yellow flowers give way to pink/brown seed capsules, fruit drop, street tree, not suited to small lots.	
<i>Quercus macrocarpa</i>	Fagaceae	Burr Oak			x	x			x	Bi,Be,H	70-80'	80'	S	50'	P, D			Large, grows to 150' deep in soils, golf-ball-size acorns, requires well drained soils, drought tolerant, street tree.	
<i>Magnolia grandiflora</i>	Magnoliaceae	Magnolia			x				x		50-60'	30'	M	30-50'	P,E	Summer	White	Large, deep rooted, needs lots of room, can be messy	
<i>Bauhinia x blakeana</i>	Caesalpiniaceae	Hong Kong Orchid				x			x	Be, Bu	30-40'	30'	M	25-30'	P, E	Spring, summer	Pink, Magenta	Sterile, no pod production, prefers acid soils, native to China, street trees, parking lots w/100-200 sq. ft. islands, tolerate some shade, no thorns. Showy flowers	
<i>Delonix regia</i>	Fabaceae	Royal Poinciana				x			x	Bu	40'	60'	F	50'	P	Summer	red/orange	Shade, requires pruning to develop strong structure. Plant 12 to 15' away from pavement. Up to 10 years to mature, produce flowers and seeds. Pod litter.	
<i>Morus rubra</i>	Moraceae	Red Mulberry			x	x			x	Bi	30' - 40'	20' x 30'	M	1"-30"P	P, D	Spring	inconspicuous	Require Female for fruit, edible - birds and humans, messy over drives and walkways.	
Tall Trees																			
<i>Callistemon citrinus</i>	Myrtaceae	Bottlebrush				x			x	Be, H	15'	10-15'	M	8-10'	P, E	Summer	Red	Colorful hedge, screen plant, parking lot islands of 100-200 feet.	
<i>Bauhinia mexicana</i>	Caesalpiniaceae	Mexican Orchid Tree				x			x	Be, Bu	12-15'	10-12'	M	10-15'	P, D	Fall, Spring	White, Pink	Lovely in bloom, excellent shade tree, small patio tree.	
<i>Chilopsis linearis</i>	Bignoniaceae	Desert willow				x			x	Be,Bu	20'	25'	M	15-20'	P, D	Summer	White, pink, purple	Prune for dense growth and more flowers, root rot if overwatered, native to West Texas.	
<i>Psidium guajava</i>	Myrtaceae	Guava				x			x	Be, Bu	20-25'	20'	F	25'	P, E	Spring	white, off-white	Must be pruned to develop strong framework. Requires supplemental water during fruiting, needs good drainage. A favorite of the Guava Skipper Butterfly.	
Small Trees																			
<i>Eriobotrya japonica</i>	Rosaceae	Loquat, Japanese plum				x			x	Be, Bu, Bi	12-15'	15'	M	12'	P, E	Fall	Off-white	Fragrant flowers, edible orange fruit, specimen tree. Drought resistant, once established. Ripen fruit falls - avoid driveways and pool areas.	

Scientific Name	Family	Common Name(s)	Aquatic	Moist Soils	Riparian	Upland	Full Shade	Shade/Sun	Full Sun	Attracts Wildlife (B=Bird Bu=Butterfly Be=Bee H=Hummingbirds)	Mature Height	Mature Width	Growth Rate (Fast, Medium, Slow)	Spacing	Lifespan: P= Perennial, A=Annual, D=deciduous E=Evergreen SE=semievergreen	Blooming Period	Bloom Color	COMMENTS	
<i>Vitex agnus-castus</i>	Verbenaceae	Vitex, Chaste Tree				x			x	Be, Bu	10-15'	15-20'	F	15-20'	P, D	Summer	white, lavender	Accent, small specimen tree, attracts butterflies, short lived, requires pruning in January to encourage blooming. Small patio tree. Requires good drainage.	
<i>Punica granatum</i>	Punicaceae	Pomegranate				x			x	Be, Bi	10-15'	8-10'	M	8'	P, D	Summer	red/orange	Edible red fruit best produced from simple flowering types, not double flowers. Heat and drought tolerant. Need good drainage. Water during fruit development.	
Shrub																			
<i>Bougainvillea glabra</i>	Nyctaginaceae	Bougainvillea				x			x	Bi	12-15'	8'	F	6-8'	P, E	Summer, Fall	numerous	Several species grow well, some need support, drought tolerant, thorny, require good drainage, cover for birds.	
<i>Caesalpinia gilliesii</i>	Caesalpinaceae	Red Bird of Paradise				x			x	Bu	8-15'	10-15'	F	8-10'	P, D	Summer, Fall	yellow/red	Train as small tree, requires good drainage, drought tolerant, native to So. America, toxic seeds, colorful.	
<i>Caesalpinia mexicana</i>	Caesalpinaceae	Mexican Caesalpinia				x			x	Bu	10-15'	10-15'	F	10'	P, D	Summer, Fall	yellow	Colorful, train as patio tree, requires good drainage, small parking lot islands, no thorns, drought tolerant, toxic seeds. Native of Mexico.	
<i>Carissa macrocarpa</i>	Apocynaceae	Natal Plum				x			x		7-10'	5-7'	F, M	6-8'	P, E	Summer	White	Also dwarf <i>Carissa macrocarpa</i> nana. Fruits make jam. Prune to control shape, hedges, drought tolerant, thorny, well drained soil. Native Southern Asia, East Africa.	
<i>Cassia alata</i>	Caesalpinaceae	Candletree, Candle Bush				x			x		5-7'	5-7'	F	8-10'	P, E	Summer	Yellow	Large, rounded shrub, use as background, showy yellow flowers, large bean, requires well drained soils.	
<i>Cuphea micropetala</i>	Lythraceae	Cigar Plant				x			x	H	6-8'	6-8'	F	5-6'	P, E	Summer	orange/red	Background plant or hedge, prune after flowering, tubular shaped flowers.	
<i>Duranta repens</i>	Verbenaceae	Duranta				x			x	Be, Bi, Bu	12-18'	5-8'	F	5-7'	P, E	Spring, Summer	purple, white	Produces golden fruit, native to South America, can be trained as a small tree, flowers in long cluster, hedge, windbreak, or specimen tree. Fruit is poisonous to humans. May die in freeze.	
<i>Hamelia patens</i>	Rubiaceae	Mexican firebush				x			x	H	2-3'	2'	F	2-3'	P, E	Summer	orange	Drought tolerant, flowering all summer, prune after flowering to retain shape.	
<i>Hibiscus species</i>	Malvaceae	Hibiscus				x			x		3-12'	6'-8'	F	5-8'	P, E	Summer	numerous	Several species, all showy flowers, medium water, well drained soils.	
<i>Hibiscus syriacus</i>	Malvaceae	Rose of Sharon, Althea				x			x	Be	10-15'	8-10'	M	8-10'	P, E	Summer	white, purple, pink	Well-drained soils, tall shrub, old fashioned southern garden plant., drought tolerant once established.	
<i>Ixora coccinea</i>	Rubiaceae	Ixora				x			x	H	3-4'	3'	M	3-4'	P, E	Summer-fall	red, yellow, orange, white	Requires regular fertilizer, medium water.	
<i>Jasminum species</i>	Oleaceae	Jasmine				x			x		4-8'	4-6'	F, M	6'	P, E	Summer	white, yellow	several species grow well, some drought tolerant, fragrant, require pruning to retain shape.	

Scientific Name	Family	Common Name(s)	Aquatic	Moist Soils	Riparian	Upland	Full Shade	Shade/Sun	Full Sun	Attracts Wildlife (B=Bird Bu=Butterfly Be=Bee H=hummingbirds)	Mature Height	Mature Width	Growth Rate (Fast, Medium, Slow)	Spacing	Lifespan: P= Perennial, A=Annual, D=deciduous E=Evergreen, SE=semi-evergreen	Blooming Period	Bloom Color	COMMENTS	
<i>Jatropha species</i>	Euphorbiaceae	Jathropa				x			x		5-8'	5-6'	F	6'	P, E	Summer	red	Several species grow well, some drought tolerant, require pruning to retain shape, disease resistant, tender tropicals, may freeze in extreme cold.	
<i>Justicia spicigera</i>	Acanthaceae	Mexican Honeysuckle				x			x	Be, H	4'	4'	F	4'	P, E	Summer	orange	Tube shaped flowers, drought tolerant, herbaceous shrub, prune after flowering to retain shape.	
<i>Lantana species</i>	Verbenaceae	Lantana				x			x	Bi, Be, H	2-4'	4'	F	4-5'	P, E	Spring, Summer	numerous	Several species grow well, drought tolerant, require well drained soils, improved varieties more disease resistant.	
<i>Nerium oleander</i>	Apocynaceae	Oleander				x			x		5-15'	5-10'	F	4-8'	P, E	Summer	numerous	Toxic, tropical origins, several varieties, including dwarf, hedge, medians, screen, all parts toxic, overused.	
<i>Plumbago auriculata</i>	Plumbaginaeae	Plumbago				x		x	x	Bu	4'	4-6'	F	4-6'	P, E	Summer to Fall	blue, white	Reliable herbaceous shrub, drought tolerant, disease and pest resistant, also <i>Plumbago capensis</i> .	
<i>Plumeria species</i>	Apocynaceae	Plumeria, Frangipani				x		x	x		6-8'	4'	M	4-5'	P, D	Summer to Fall	numerous	Highly fragrant at night - lures moths, no nectar, requires good drainage, native to tropical areas. Can be a tall shrub, small tree shape.	
<i>Rosa</i>	Rosaceae	Rose				x			x		2-8'	4-6'	M	4-5'	P, E	Summer	numerous	Antique roses or roses on Mexican root stock perform best. Require improved soils, mulch.	
<i>Tabernaemontana coronaria</i>	Apocynaceae	Mock Gardenia, Butterfly Gardenia				x			x		4-6'	4'	M	5-6'	P, E	Summer	white	Fragrant, requires irrigation during summer, prune to shape	
<i>Tecoma stans</i>	Bignoniaceae	Esperanza, Yellow Bells				x			x	Be, Bu, H	to 15'	8'	F	6-8'	P, E	Summer	yellow, orange	Requires well drained soil, tall shrub, can train as small tree, disease and pest resistant.	
<i>Tecomaria capensis</i>	Bignoniaceae	Cape Honeysuckle				x			x	Be, H	7-10'	4-5'	F	5'	P, E	Summer	orange	Tube shaped flowers, part climbing, prune to control trailing growth and suckering, performs best in improved, well drained soils.	
Herbaceous																			
<i>Artemisia species</i>	Asteraceae	Artemisia				x		x	x		1.5-3'	2'	F	3'	P, E			Several species, grown for foliage, tall ground cover with some sun, prune in Jan/Feb, contact plant with grey or green foliage. Drought tolerant, requires well drained soils.	
<i>Hesperaloe parviflora</i>	Agavaceae	Red Yucca				x			x	Bu, H	3'	2'	M	3-4'	P, E	Summer	coral	Extremely drought tolerant, disease resistant, excellent in xeric gardens, rock gardens.	
<i>Melampodium leucanthum</i>	Asteraceae	Blackfoot daisy				x			x	Be, Bu	12"	12-15"	F	12"	P	Summer	white	Drought tolerant, requires sandy, well-drained soils, small sunflower-type flower, native to central Texas. Dies to ground in winter.	
<i>Pentas lanceolata</i>	Rubiaceae	Penta				x		x	x	Bu, H	2'	18-24"	F	18"	P, E	Summer	numerous	This is a short lived perennial in so. Texas, annual in most areas. Attracts butterflies, hummingbirds. Plant in clusters or front of flower beds.	

Scientific Name	Family	Common Name(s)	Aquatic	Moist Soils	Riparian	Upland	Full Shade	Shade/Sun	Full Sun	Attracts Wildlife (B=Bird Bu=Butterfly Be=Bee H=Hummingbirds)	Mature Height	Mature Width	Growth Rate (Fast, Medium, Slow)	Spacing	Lifespan: P= Perennial, A=Annual, D=deciduous E=Evergreen SE=semi-evergreen	Blooming Period	Bloom Color	COMMENTS
<i>Rosmarinus officinalis</i>	Lamiaceae	Rosemary				x			x	Bu	2'	18"-24"	M	18"	P, E	Summer	blue, pink, white	Several species, grown for foliage, drought tolerant and requires very well drained soils. Plant in Xeric gardens, rock gardens. Some species upright growth habit, some trailing.
<i>Salvia leucantha</i>	Lamiaceae	Mexican Bush Sage				x			x	Be, Bu, H	3'	3'	F	3'	P, E	Summer to Fall	purple	Semi-woody shrub, butterfly gardens, prune after flowering to retain shape, mass plantings, xeric gardens, drought tolerant, once established, disease resistant.
<i>Stachytarpheta mutabilis</i>	Verbenaceae	Dwarf Porterweed				x			x	Be, Bu, H	2'-3'	2-3'	F	2.5'	P, E	Summer to Fall	red	Drought tolerant, well-drained soils. May die in freeze.
<i>Stachytarpheta jamaicensis</i>	Verbenaceae	Porterweed				x			x	Be, Bu, H	4-6'	4-6'	F	4'	P, E	Summer	blue	hedge, mass planting, butterfly plant, trim after flowering to retain shape. Drought tolerant, well-drained soils, can become invasive.
<i>Wedelia hispida</i>	Asteraceae	Wedelia, Zexmenia				x			x	Be, Bu, H	3'	2'	F	2-2.5'	P, E	Summer	yellow	Ground cover, flowers all summer, best in full sun.
Vine																		
<i>Antigonon leptopus</i>		Coral vine				x			x	Bu			F	4'	P	Summer	pink/coral	Fast growing vine. Will tolerate partial shade, can be trained to grow up trees.
		Mexican Love Vine				x			x	Bu			F	4'	P	Summer	orange	Fast growing, will die back in hard freeze.
		Bleeding Heart								Be, Bu			M, F	4-6'	P	Summer to Fall	pink/purple/red	Multi-colored flowers, slow growing to start, but once established can be aggressive. Responds to trimming. Will drop some leaves in cold weather.

(APPENDIX B)

Edinburg Prohibited Plant List

Scientific Name	Common Name
<i>Alhagia camelorum</i>	Camelthorn
<i>Alternanthera philoxeroides</i>	Alligatorweed
<i>Arundo donax</i>	Giant Reed
<i>Calystegia sepium</i>	Hedge Bindweed
<i>Convolvulus arvensis</i>	Field Bindweed
<i>Coscuta japonica</i>	Japanese Dodder
<i>Eichornia azurea</i>	Rooted Water Hyacinth
<i>Eichornia crassipes</i>	Common Water Hyacinth
<i>Hydrilla verticillata</i>	Hydrilla
<i>Ipomea aquatica</i>	Water Spinach
<i>Lagarosiphon major</i>	Lagarosiphon
<i>Leucaena leucocephala</i>	Popinac
<i>Lythrum salicaria</i>	Purple Loosestrife
<i>Melaleuca quinquenervia</i>	Paperbark
<i>Melia acedarach</i>	Chinaberry
<i>Pistia stratiotes</i>	Water Lettuce
<i>Pueraria lobata</i>	Kudzu
<i>Ricinus communis</i>	Castorbean
<i>Schinus terebinthifolius</i>	Brazilian Peppertree
<i>Tamarix ramosissima</i>	Salt Cedar, Tamarisk
<i>Sapium sebiferum</i>	Chinese Tallowtree

APPENDIX C: BIBLIOGRAPHY

Sources Cited

- American Forests and National Association of Home Builders. Building Greener Neighborhoods. 2nd ed. Washington, DC: American Forests, 1998.
- Burditt Associates. Urban Forest Management Plan, City of College Station, Texas. Conroe, TX: Burditt Associates, 2002.
- Council of Tree and Landscape Appraisers. Guide for Plant Appraisal. 9th ed. Champaign, IL: International Society of Arboriculture, 2000.
- Dockter, Dave. Tree Technical Manual, Standards and Specifications. Palo Alto, CA: City of Palo Alto, Department of Planning and Community Development, 2001.
- Elmendorf, William. A Guide to Preserving Trees in Development Projects. University Park, PA: Pennsylvania State University, School of Forest Resources, 1999.
- Minnesota Department of Natural Resources, Division of Forestry. Conserving Wooded Areas in Developing Communities: Best Management Practices in Minnesota. St Paul, MN: Minnesota Department of Natural Resources, Division of Natural Resources, 1999.
- Peltier, Patrice and Gary W. Watson. "Transplanting Trees, Part 1: Preparing the Plant and Site for a Successful Move." *Arbor Age* January 2000: 8-15.
- Peltier, Patrice and Gary W. Watson. "Transplanting Trees, Part 2: Improve Your Tree Transplanting Survival Rates with These Transportation and Storage Tips." *Arbor Age* February 2000: 8-13.
- Peltier, Patrice and Gary W. Watson. "Transplanting Trees, Part 1: The "After Care" of Transplanting Trees Is the Most Critical Step." *Arbor Age* March 2000: 8-15.
- Seattle, Urban Forest Coalition. A City Among the Trees, An Urban Forestry Resource Guide. Seattle, WA: City of Seattle, 1998.
- TreeFolks. Tree Planting Guide. Austin, Texas: Tree Folks, 2000.
- Watson, Gary W. and E. B. Himelick. Principles and Practice of Planting Trees and Shrubs. Savoy, IL: International Society of Arboriculture, 1997.

Additional Resources

- American Association of Nurserymen. American Standard for Nursery Stock, ANSI Z60.1-1996. Washington, DC: American Association of Nurserymen, 1997.
- ANSI Z133.1-1994. American National Standards Institute Standard for Tree Care Operations—Pruning, Trimming, Repairing, Maintaining and Removing Trees, and Cutting Brush—Safety Requirements.
- ANZI A300-1995. American National Standards Institute Standard for Tree Care Operations—Pruning, Trimming, Repairing, Maintaining, and Removing Trees and Cutting Brush—Standard Practice.

Appendix C-2

- Clark, James R., Richard W. Harris and Nelda P. Matheny. *Arboriculture Integrated Management of Landscape Trees, Shrubs, And Vines*. 3rd ed. Upper Saddle River, NJ: Prentice Hall, 1999.
- Gilman, Edward F. *An Illustrated Guide to Pruning*. 2nd ed. Albany, NY: Delmar, 2002.
- Matheny, Nelda and James R. Clark. *Trees and Development, A Technical Guide to Preservation of Trees During Land Development*. Champaign, IL: International Society of Arboriculture, 1998.
- Miller, Nancy L., David M. Rathke, and Gary R. Johnson. *Protecting Trees from Construction Damage, A Homeowner's Guide*. St. Paul, MN: University of Minnesota, Minnesota Extension Service, 1993.
- Moll, Gary and Stanley Young. *Growing Greener Cities A Tree-Planting Handbook*. Venice, CA: Living Planet Press, 1992.
- Pirone, Thomas P., John R. Hartman and Mary Ann Sall. *Pirone's Tree Maintenance*. 7th ed. Oxford, NY: Oxford University Press, 2000.
- Shigo, Alex L. *Tree Pruning A Worldwide Photo Guide*. Durham, NH: Shigo and Trees, Associates, 1989.
- Texas Association of Nurseryman. *Grades and Standards*. Austin, TX: Texas Association of Nurseryman, n.d.
- TreePeople. *The Simple Act of Planting a Tree: A Citizen Forester's Guide to Healing Your Neighborhood, Your City, and Your World*. Los Angeles, CA: Tarcher, 1990.

Planning & Zoning Department

PROTECTED TREE REMOVAL APPLICATION FORM

Date of Application: _____	Name of Applicant: _____
Address of Property where trees are located: _____	
Legal Description: _____	
Name of owner if different from applicant: _____	
Applicant's day phone number: _____	Fax number: _____
E-mail address: _____	

Tree species: _____		
Size of tree in inches (measure 4'6" from ground)		
Circumference _____	or	Diameter _____

General condition of tree(s):

Reasons for removal:

To expedite this request, please provide photographs of the tree(s) and provide a plan view sketch showing the location of the tree as it is sited on the property as specified in the Tree Technical Manual. The application is required ONLY when a request for tree removal originates with an owner of fully developed land, including a single family house under construction. All other requests for removal of protected trees take place during the subdivision and site development processes as defined in the Unified Development Code. Additional information may be required by the Forestry Manager.

Applicant's Signature _____ Date: _____

DEPARTMENT USE ONLY

Forestry Manager Comments/Conditions of Approval:

Approval By: _____ Date: _____

Fee: \$150.00